



**South Lake County Fire Protection District**  
— in cooperation with —  
**California Department of Forestry and Fire Protection**

---

P.O. Box 1360 Middletown, CA 95461 - (707) 987-3089

**NOTICE:** Pursuant to Governor Gavin Newsom's Executive Order N-29-20, meetings will be held teleconference. Teleconference participation by: Directors Rob Bostock, Jim Comisky, Devin Hoberg, Madelyn Martinelli and Eric Redford. Teleconference locations are on file at District Office, 21095 Highway 175, Middletown, CA 95461.

Due to the Coronavirus (COVID-19), Residents are encouraged to attend the Board of Directors' meeting via the application, ZOOM.

ZOOM MEETING INFORMATION:

Website: <https://zoom.us/join>

Meeting ID: 868 2132 0090

Call in Phone Number: (669) 900 6833

Public comments may be made remotely by emailing [boardclerk@southlakecountyfire.org](mailto:boardclerk@southlakecountyfire.org) (prior to 6:30 pm) or via ZOOM website or phone application. Comment period is three (3) minutes per person. Total comment period is not to exceed fifteen (15) minutes, unless extended at the discretion of the Board. This rule does not apply to public hearings. Comments are allowed before any action is taken by the Board on any specific issue.

**BOARD OF DIRECTORS' REGULAR MEETING AGENDA**

**7:00 P.M., December 15, 2020**

**Middletown Fire Station, 21095 Highway 175**

**NON-TIMED ITEMS**

**A. OPEN MEETING:**

A1. Call to Order:

A2. Pledge of Allegiance:

A3. Roll Call:

A4. Motion to approve agenda:

MOVED \_\_\_\_\_ SECONDED \_\_\_\_\_ YES \_\_\_ NO \_\_\_ ABSTAIN \_\_\_

A5. Administer Oaths of Office for 1) Rob Bostock, James F. Comisky and Madelyn L. Martinelli, who are appointed to four-year terms; 2) For Eric Redford who was appointed to a two-year unexpired term

**B. CITIZENS' INPUT:**

(Any person may speak for three minutes about any subject of concern provided it is within the jurisdiction of the Board of Directors and is not already on the today's agenda. Prior to this time speakers are asked to fill out a form (giving name, city, and subject) available in the Clerk's Office or during Board meeting.)

**C. COMMUNICATIONS:**

C1. Reports:

C1.1. Fire Sirens

C1.2. SL Fire Safe Council

C1.3. Volunteer Firefighters' Association

C1.4. Chief's Report

- C1.5. Financial Report
- C2. Directors' Activity and Committee Report

**TIMED ITEMS**

**D. REGULAR ITEM:**

D1. Consideration for Resolution No. 2020-21-08, A Resolution Ratifying the Canvass of Election Returns from the County of Lake Registrar of Voters Office for General Election of November 3, 2020, and Adopting and Ratifying Results for Measure O. Placed on agenda by SSA Gloria Fong.

MOVED \_\_\_\_\_ SECONDED \_\_\_\_\_ YES \_\_\_ NO \_\_\_ ABSTAIN \_\_\_

D2. Consideration for Resolution No. 2020-21-09, A Resolution Transferring and Appropriating Contingencies, and Establishing and Appropriating Over-Realized / Unanticipated Revenues from Insurance and Sales Proceeds for Repurposing of 2003 Chevrolet Ambulance to Type 6 Engine 6061 and Its Repairs. Placed on agenda by Chief Paul Duncan, Battalion Chief Mike Wink, and Association President Todd Fenk.

MOVED \_\_\_\_\_ SECONDED \_\_\_\_\_ YES \_\_\_ NO \_\_\_ ABSTAIN \_\_\_

D3. Consideration for Resolution No. 2020-21-10, A Resolution Transferring and Appropriating Contingencies for Repeater to Improve Communications in Southern End of Lake County. Placed on agenda by Battalion Chief Mike Wink.

MOVED \_\_\_\_\_ SECONDED \_\_\_\_\_ YES \_\_\_ NO \_\_\_ ABSTAIN \_\_\_

D4. Consideration for Resolution No. 2020-21-11, A Resolution Accepting Fiscal Year 2019 Assistance to Firefighters Grant (AFG), and Establishing and Appropriating Over-Realized / Unanticipated Revenues from AFT and Fire Mitigation Fees for Purpose of Purchasing of Self Contained Breathing (SCBA) Units. Placed on agenda by SSA Gloria Fong.

MOVED \_\_\_\_\_ SECONDED \_\_\_\_\_ YES \_\_\_ NO \_\_\_ ABSTAIN \_\_\_

D5. Consideration for Resolution No. 2020-21-12, A Resolution Pertaining to Tax Revenue Exchange for Jackson, Polanco, and Rancheria Annex to Callayomi County Water District – LAFCO Project #2020-001. Placed on agenda by SSA Gloria Fong.

MOVED \_\_\_\_\_ SECONDED \_\_\_\_\_ YES \_\_\_ NO \_\_\_ ABSTAIN \_\_\_

**E. CONSENT CALENDAR:**

(Approval of consent agenda items are expected to be routine and non-controversial. They will be acted upon by the Board at one time without discussion. Any Board member may request that an item be removed from the consent calendar for later discussion.)

E1. Minutes presented:

E1.1. November 17, 2020 – Regular Meeting

E2. Warrants presented:

E2.1. December - Preliminary

E2.2. November - Corrected

E3. Budget Transfer

E4. Surplus 1985 International, previously Engine 6032, recently replaced with 1999 International.

MOVED \_\_\_\_\_ SECONDED \_\_\_\_\_ YES \_\_\_ NO \_\_\_ ABSTAIN \_\_\_

F. MOTION TO ADJOURN MEETING:

Posted December 11, 2020



**COUNTY OF LAKE**  
**Registrar of Voters Office**  
**Courthouse – 255 North Forbes Street**  
**Lakeport, CA 95453**  
**Telephone 707/263-2372**  
**FAX 707/263-2742**

**MARIA VALADEZ**  
**Registrar of Voters**

**LOURDES PANTALEON**  
**Deputy Registrar of Voters**

December 3, 2020

South Lake County Fire Protection District  
Gloria Fong, District Secretary  
Gloria.Fong@fire.ca.gov

Dear Gloria:

Please find attached the "Certificate of Appointment of Fire Protection District Director In Lieu of Election and Oath of Office" forms for Rob Bostock, James F. Comisky II and Madelyn L. Martinelli who were appointed to four-year terms; and, Eric Redford who was appointed to a 2-year unexpired term following the adoption of Resolution No. 2020-158 by the Lake County Board of Supervisors on November 3, 2020. The directors may be sworn in to begin their new terms of office at a special or regular District Board of Directors meeting held on or following December 4, 2020. Please print two (2) originals, and after each director has subscribed to the Oath of Office, return an original Certificate of Appointment and Oath of Office form for each Director to the Registrar of Voters office.

If you have any questions, please contact me or Lourdes in the Registrar of Voters office or by phone at 263-2372.

Sincerely,

Maria Valadez  
Registrar of Voters

cc: Rob Bostock, James F. Comisky II, Madelyn L. Martinelli and Eric Redford

**North Division Operations:**

Staffing is holding for now at 1-Engine per station, through the 27<sup>th</sup> of December. If weather continues to be wet, more down staffing is anticipated.

More delays on the new helicopter, now anticipated to be May of 2021. Crews will be doing lots of training over the weekend in anticipation of delivery. Residents may see one of the new helicopters around the area, as we work to get the crews trained ahead of the delivery.

Progress is being made on the Station 31 remodel and asbestos removal project, with an anticipated 'move-in' date of February, 2021. As we transition to a winter mode, other crews will be assisting with the Station 31 remodel.

There will be 3 new engines that we will be outfitting to replace older engines in the Division.

**Camp Operations:**

Chamberlin Creek Camp needed to have crews placed while their camp was preparing for their depopulation, so Konocti gained 2 crews temporarily. For the next couple of weeks, we will have 4 crews available for projects, in addition to extra in-camp personnel.

**South Lake Operations:**

The new SCBA's under the Lake County \$970,000 FEMA Grant have been delivered, inventoried and placed into service. The crews are excited with the new equipment, and an enhancement to our operational capabilities.

Thanks to Chief Wink, several small grants have been received for special projects:

- A Fire Extinguisher and Smoke Alarm give away
- County Map Book Update
- Evacuation Pre-Attack Map Production
- Jerusalem Valley Road Sign and Address Update
- Wildland Fire Hand tools for First Responders and Citizens

Station 64 repairs are progressing

The Fire Siren Wish List 2020 items are being purchased.

Burn and Building Permit forms are being converted to online. This will keep our office staff from having unnecessary public contact, and streamline operations.

Office Technician interviews will be conducted next week. COVID precautions have caused us to switch to an online interview format.

Fire Captain Marc Hottendorf has returned to the Fire District as a Fire Captain Paramedic.

Our Amador season is delayed, due to the extension of Fire Season. We need a significant season-ending rain event.

End of Report

Paul Duncan – Fire Chief

# CDF/SLCF INCIDENT TRACKING FORM

**Month**                      **November 2020**

**Station 62**

FA = False Alarm  
 CR = Cancel & Return  
 UTL = Unable To Locate  
 AMA = Against Medical Advice  
 CB = Code Blue (Full Arrest, CPR in Progress)  
 LA = Lift Assist  
 NMM = No Medical Merit (AMA not completed)

NRS complete ✓	Date	Time of Dispatch	Time Committed	Time At Scene	Time Available	Inc. #	Location Location	Street Name	Medical Aid	MVA	Structure Fire	Vegetation Fire	Vehicle Fire	Smoke Check	Haz-Mat	Public Assist	Other (Describe)	# of Fatalities	Extrication Eff Used	Comments: List Number of Patients as Pt x 4 If an IFT, List Destination Here Any Specific Comments, List Here
	11/2	1423	1425	1436	1525	18344	Sycamore Rd		1											1PTC2AHC
	11/2	2020	2021		2045	18367	Black Oak								1					UTL
	11/3	0026	0026		0029	18376	Harness Dr, PV		2											CR
	11/3	1358	1359	1423	1439	18409	Mombacho Rd										1			LA
	11/5	1440	1442	1504	1513	18520	S HWY 29/ Butts Canyon Rd			1										Pt flown Calstar 4
	11/6	0834	0834		0835	18564	High Valley Rd								2					CR
	11/6	1025	1027	1037	1040	18567	Mead Rd								3					UTL
	11/7	1304	1306	1316	1340	18639	Ridge Rd.		3											NMM
	11/7	1619	1621	1630	1545	18652	Fox Dr.		4											1 PT C2 AHC
	11/8	1355	1356		1358	18713	Douglas st X HWY 29			2										CR
	11/9	1552	1552		1557	18777	HWY 175			3										UTL
	11/10	0244	0248	0308	0500	18803	Saddle Rd				1									Str/Veg Fire
	11/10	1110	1114	1118	1125	18820	Mountain Medows		5											CR
	11/10	2243	2245	2255	2258	18854	Sycamore Rd										2			LA
	11/11	0640	0642	0657	0658	18862	Sycamore Rd										3			LA
	11/11	1614	1614		1632	18896	Fairway Dr, KV				2									Res Alarm CR
	11/11	1754	1754		1801	18903	Deer Hill, HV		6											CR
	11/11	1933	1933	1943	1852	18912	Sycamore Rd										4			Welfare Check, NMM
	11/12	1054	1055	1113	1313	18944	Powder Horn Rd				3									
	11/12	1949	1953	2006	2042	18982	Bottle Rock Rd					1								
	11/13	0733	0736	0743	0759	19006	Bottle Rock Rd		7											1144
	11/13	1157	1157	1209	1222	19019	Sycamore Rd										5			LA
	11/13	1812	1813		1826	19064	Highway 175			4										UTL
	11/13	1928	1930		1946	19071	Harrington Flat Rd											1		Haz, electrical UTL
	11/14	1458	1500	1508	1516	19114	HWY 175		8											NMM
	11/15	1322	1323	1331	1509	19153	Bottle Rock Rd		9											1 PT C2 sutter
	11/15	1746	1748	1753	1911	19173	Oak st		10											1 PT C2 AHC
	11/18	2316	2317	2323	2351	19357	Putter Rd		11											NMM
	11/20	1549	1551	1556	1611	19451	Santa Barbara Ave										6			LA
	11/20	2318	2320	2326	2344	19468	Bottle Rock Rd		12											NMM
	11/22	1313	1315	1326	1453	19554	Ridge rd		13											1 PT C2 AHC
	11/22	2223	2226	2238	0016	19588	Angelly		14											1 PT C2 AHC
	11/23	1434	1438	1454	1702	19632	Seigler Canyon						2							Veg Fire

# CDF/SLCF INCIDENT TRACKING FORM

Month                                  November 2020

Station 62

FA = False Alarm  
 CR = Cancel & Return  
 UTL = Unable To Locate  
 AMA = Against Medical Advice  
 CB = Code Blue (Full Arrest,CPR in Progress)  
 LA = Lift Assist  
 NMM = No Medical Merit (AMA not completed)

NRS complete ✓	Date	Time of Dispatch	Time Committed	Time At Scene	Time Available	Inc. #	Location Location	Street Name	Medical Aid	MVA	Structure Fire	Vegetation Fire	Vehicle Fire	Smoke Check	Haz-Mat	Public Assist	Other (Describe)	# of Fatalities	Extraction Eqt Used	Comments:	
	11/24	1551	1551	1601	1713	19696	Sycamore Rd		15											1PT C2 AHC	
	11/26	1125	1127		1237	19800	Bottle Rock Rd								1					Smoke check	
	11/26	1311	1313		1350	19810	HWY 175											2		aircraft crash UTL	
	11/26	1403	1403		1413	19812	Salmina rd											3		medical pendant CR	
	11/28	1714	1715	1719	1754	19884	Dogwood Way		16											AMA	
	11/28	0536	0538	0545	0605	19913	Golf Rd		17											NMM	
	11/28	0719	0721	0736	0921	19915	Black Oak Rd		18											CB	
	11/30	1313	1314	1319	1321	20026	Brookside Dr										7			LA	
	11/30	1803	1805	1814	1831	20045	Sycamore Rd		19											NMM	
	11/30	2237	2240		2251	20057	HWY 175 X HWY 29							1						CX	
									<b>TOTALS:</b>	19	4	3	2	1	4	0	7	3	0	0	
									<b>PREVIOUS:</b>	183	64	19	24	9	16	3	28	30	0	0	
									<b>YEAR TO DATE:</b>	202	68	22	26	10	20	3	35	33	0	0	

**Comments:**  
**List Number of Patients as Pt x 4**  
**If an IFT, List Destination Here**  
**Any Specific Comments, List Here**

# CDF/SLCF INCIDENT TRACKING FORM

Month November 2020

Station 63

FA = False Alarm  
 CR = Cancel & Return  
 UTL = Unable To Locate  
 AMA = Against Medical Advice  
 CB = Code Blue (Full Arrest, CPR in Progress)  
 LA = Lift Assist  
 NMM = No Medical Merit (AMA not completed)

**Comments:**  
**List Number of Patients as Pt x 4**  
**If an IFT, List Destination Here**  
**Any Specific Comments, List Here**

CAIRS complete ✓	Date	Time of Dispatch	Time Committed	Time At Scene	Time Available	Inc. #	Location		Medical Aid	MVA	Structure Fire	Vegetation Fire	Vehicle Fire	Smoke Check	Haz-Met	Public Assist	Other (Describe)	# of Fatalities	Extrication Eqt Used	Comments
							Street #	Street Name												
	11/1	0342	0344	0411	0411	18255		RLS			1									CR
	11/1	1301	1301	1301	1353	18283		Station 63		1										NMM
	11/2	0906	0908	0930	0959	18323	3820	Pearl Ave		2										NMM
	11/2	1355	1357	1427	1537	18342	15367	McKell Rd		3										1 Pt C2 to AHC
	11/3	0026	0028		0147	18376	2624	Harness Dr		4										CR
	11/3	0328	0330	0345	0519	18380	19750	East Rd		5										1 Pt C2 to AHC
	11/3	0519	0521	0524	0535	18381	18135	Green Point Ct									1			Lift Assist
	11/3	0909	0912	0915	0920	18392	18135	Green Point Ct									2			Lift Assist
	11/3	1149	1151	1200	1220	18402	15514	Plateau Ct									3			Lift Assist
	11/4	0007	0009	0013	0030	18441	18358	lakeridge Cir									4			Smoke removal
	11/4	0138	0141	0147	0200	18442	16906	Greenridge Rd		6										NMM
	11/4	0732	0734	0740	0843	18452	16906	Greenridge Rd		7										1 Pt C2 to AHC
	11/4	1441	1443		1450	18475	21605	Dry Creek Cut-Off									5			Lift Assist
	11/5	1439	1441	1447	1610	18520	20832	Highway 29			2									1 Pt to CAL STAR 4 SRMH
	11/6	2149	2151	2154	2223	18603	18453	Hidden Valley Rd									6			Lift Assist
	11/6	2203	2206	2211	2217	18604	18801	Fernwood										1		Lines Down
	11/7	0358	0400	0404	0451	18613	18111	Hidden Valley Rd		8										1 Pt C3 to AHC
	11/7	0957	1001	1003	1019	18631	18135	Greenpoint Ct									7			Lift Assist
	11/8	1225	1228		1235	18706		Hwy 29 X Hofacker			3									CR
	11/8	1353	1357	1402	1428	18713		Calistoga X Douglas			4									Non Injury
	11/8	1522	1527	1536	1636	18715	18770	Glencove		9										1 Pt C2 to AHC
	11/9	1337	1339	1352	1506	18764	19040	redbud road		10										1 Pt C2 to AHC
	11/9	1552	1554		1557	18777	17114	Hwy 175			5									CR
	11/9	1721	1723	1733	1733	18783	15851	Armstrong st		11										1 Pt C3 to AHC
	11/9	2116	2117	2126	2206	18792	21299	Calistoga		12										NMM
	11/10	1107	1109	1114	1222	18820	19330	MMS		13										1 PT C2 AHC
	11/10	1331	1333	1340	1410	18826		HVR/Spruce grove etx		14										NMM
	11/11	1757	1759	1804	1920	18903	18869	Deer Hill Rd		15										1 Pt to AHC
	11/12	0205	0208	0228	0253	18923	14540	Walnut		16										1 Pt to AHC ALS
	11/12	0305	0305	0314	0350	18924	3805	Dexter		17										1 Pt to AHC ALS
	11/12	1051	1053	1058	1310	18944	21155	Powderhorn				1								Attic Fire
	11/12	1735	1736	1742	1758	18974	20838	Yankee Valley Rd									8			Lift Assist
	11/12	1948				18982	15960	Bottlerock Rd					1							Cx



# CDF/SLCF INCIDENT TRACKING FORM

**Month**                      **November 2020**

**Station 63**

FA = False Alarm  
 CR = Cancel & Return  
 UTL = Unable To Locate  
 AMA = Against Medical Advice  
 CB = Code Blue (Full Arrest, CPR in Progress)  
 LA = Lift Assist  
 NMM = No Medical Merit (AMA not completed)

**Comments:**  
**List Number of Patients as Pt x 4**  
**If an IFT, List Destination Here**  
**Any Specific Comments, List Here**

CAIRS complete ✓	Date	Time of Dispatch	Time Committed	Time At Scene	Time Available	Inc. #	Locator Location		Medical Aid	MVA	Structure Fire	Vegetation Fire	Vehicle Fire	Smoke Check	Haz-Met	Public Assist	Other (Describe)	# of Fatalities	Extrication Eqt Used	Comments
							Street #	Street Name												
	11/13	0038	0041	0048	0147	18996	16906	Greenridge Rd		18										1144
	11/15	0117	0120	0128	0230	19132	22610	Western Mine Ext		19										1 Pt to AHC ALS
	11/15	0523	0525	0532	0548	19138	20683	Santa Barbara									9			Lift Assist
	11/16	1211	1213	1217	1324	19214		Twin Pine Casino		20										1 Pt to AHC
	11/17	0853	0855		0913	19261		RLS		6										CR
	11/17	1050	1052	1054	1110	19267	19309	Mountain Meadow N		21										NMM
	11/17	1256	1258	1306	1407	19276	21337	Bush St		22										1 Pt to AHC ALS
	11/17	1927	1928	1938	2044	19298	20683	Santa Barbara Ave		23										1 Pt to AHC ALS
	11/18	0755	0758		0826	19311	5150	Hwy 29		7										Non Injury
	11/18	0846	0848	0900	0922	19317	5240	Hwy 29		8										Non Injury
	11/18	0944	0944	0958	1056	19324	20683	Santa Barbara										1		IFT from AHC to Residence
	11/18	2056	2058		2110	19353	41	Hwy 29		9										Cx
	11/19	1013	1013	1020	1040	19373	21095	Highway 175		24										NMM
	11/20	0454	0456	0500	0513	19418	18135	Green Point Ct									10			Lift Assist
	11/20	1534	1534	1536	1549	19448	19461	Park Ridge		25										NMM
	11/20	1549	1549	1553	1609	19449	17294	S. Hwy 29		10										Non Injury
	11/20	1730	1733	1805	1916	19458	7300	Butts Canyon Rd		11										Mutual Aid
	11/20	2105	2107	2115	2125	19465	17937	Deer Hill Rd									11			Welfare Check
	11/21	1214	1216	1220	1330	19489	19464	Picture Point Ct		26										1 Pt to AHC
	11/21	1734	1736	1746	1800	19506	20683	Santa Barbara Ave		27										NMM
	11/23	1339	1341		1401	19623		Hwy 29 X Butts Canyon Rd										2		Debris Fire; UTL
	11/23	1441	1443		1502	19632	12185	Seigler Canyon Rd					2							Cx; Diverted
	11/23	1502	1503	1522	1523	19634	15851	Armstrong St		28										CR
	11/23	2027	2029	2037	2154	19649	21345	Bush St		29										1 Pt to AHC BLS
	11/23	2154	2155	2205	2304	19653	19175	Stonegate Rd		30										1 Pt to AHC ALS
	11/24	0235	0237	0257	0506	19667		RLS										3		Medical Rescue
	11/24	0551	0553	0559	0603	19668	16351	Conestoga Rd		31										Accidental activation of medical alarm
	11/24	1018	1019		1021	19678	21345	Bush St									12			CR
	11/25	1139	1141	1145	1200	19747	19389	Donkey Hill Rd									13			Lift Assist
	11/25	1650	1652		1720	19763		Hwy 29 X Rattlesnake Springs		12										UTL
	11/25	1958	2000	2006	2059	19774	17745	Spur Ct		32										1 Pt to Reach 6
	11/25	2110	2112	2120	2230	19777	18238	Deer Hollow Rd		33										1 Pt to AHC
	11/26	0132	0134	0145	0235	19784		Spruce Grove X Little High Valley		13										1 Pt with M7011

# CDF/SLCF INCIDENT TRACKING FORM

**Month**                      **November 2020**

**Station 63**

FA = False Alarm  
 CR = Cancel & Return  
 UTL = Unable To Locate  
 AMA = Against Medical Advice  
 CB = Code Blue (Full Arrest, CPR in Progress)  
 LA = Lift Assist  
 NMM = No Medical Merit (AMA not completed)

CAIRS complete ✓	Date	Time of Dispatch	Time Committed	Time At Scene	Time Available	Inc. #	Location Location		Medical Aid	MVA	Structure Fire	Vegetation Fire	Vehicle Fire	Smoke Check	Haz-Met	Public Assist	Other (Describe)	# of Fatalities	Extrication Eqt Used	Comments:		
							Street #	Street Name													List Number of Patients as Pt x 4 If an IFT, List Destination Here Any Specific Comments, List Here	
	11/26	0652	0654	0657	0707	19790	18917	Spyglass Rd		34											NMM	
	11/26	1144	1146	1150	1203	19803	19158	Gooselake Ct		35											NMM	
	11/26	1311	1313		1350	19810		Hwy 175 X M.M. 21.5											4		Haz; Aircraft Alert 3 - UTL	
	11/26	1653	1655	1659	1819	19823	19121	Gooselake Ct		36											1 Pt to AHC	
	11/27	0818	0819		0820	19852	21187	Calistoga St													5	Debris Fire; CR
	11/27	1344	1346	1359	1518	19871	19657	Butts Canyon Rd		37												1 Pt to AHC
	11/27	1519	1520	1525	1640	19879	19205	Gooselake Ct		38												1 Pt to AHC
<b>TOTALS:</b>										38	13	1	2	0	0	0	13	5	1	0		
<b>PREVIOUS:</b>										416	88	21	25	4	10	3	64	24	1	0		
<b>YEAR TO DATE:</b>										454	101	22	27	4	10	3	77	29	2	0		



**South Lake County Fire Protection District**  
— in cooperation with —  
**California Department of Forestry and Fire Protection**

---

P.O. Box 1360 Middletown, CA 95461 - (707) 987-3089

**DATE:** December 12, 2020  
**TO:** Board of Directors  
**FROM:** Gloria Fong  
Staff Services Analyst  
**SUBJECT:** Finance Communications

November was uneventful except for what is on the agenda. A budget summary will be sent under separate cover.



**South Lake County Fire Protection District**  
— in cooperation with —  
**California Department of Forestry and Fire Protection**

---

P.O. Box 1360 Middletown, CA 95461 - (707) 987-3089

**DATE:** December 12, 2020  
**TO:** Board of Directors  
**FROM:** Gloria Fong  
Staff Services Analyst  
**SUBJECT:** Resolution No. 2020-21-08, A Resolution Ratifying the Canvass of Election Returns from the County of Lake Registrar of Voters Office for General Election of November 3, 2020, and Adopting and Ratifying Results for Measure O

Subject resolution along with the County of Lake Registrar of Voter's Office Certification incorporated as Exhibit A is provided for Board's consideration and approval. The resolution acknowledges the election results and adopts the establishment of an annually adjusted appropriations limit, or spending limit, adjusted \$1,250,000 plus the special tax levy amount.

Resolution No. 2020-21-02 called for Special Election for the purpose of Establishing a New Appropriations Limit. Pursuant to Article XIII B of the California State Constitution, the appropriations limit may be annually adjusted for up to four years and requires two-thirds vote for passage.

Results of the November 3, 2020, General Election show 3,771 (or 68.8%) Yes and 1,707 (or 31.2%) No votes. This includes both Election Day and Vote by Mail ballots cast.

Attachments: 1) subject resolution  
2) Election Certification as Exhibit A

**BOARD OF DIRECTORS, SOUTH LAKE COUNTY FIRE PROTECTION DISTRICT**  
**COUNTY OF LAKE, STATE OF CALIFORNIA**

**RESOLUTION NO. 2020-21 -08**

**A RESOLUTION RATIFYING THE CANVASS OF ELECTION RETURNS FROM THE  
COUNTY OF LAKE REGISTRAR OF VOTERS OFFICE FOR GENERAL ELECTION OF  
NOVEMBER 3, 2020, AND ADOPTING AND RATIFYING RESULTS FOR MEASURE O**

1           **WHEREAS**, Resolution No. 2020-21-02 called for a Special Election for the Purpose of  
2 Establishing a New Appropriations Limit and requested the Board of Supervisors of the County of  
3 Lake to permit Registrar of Voters to render services necessary for the preparation of the ballots  
4 and conduct the election to be presented to the qualified registered voters encompassed by the  
5 boundaries of South Lake County Fire Protection District (Fire District) on Tuesday, November 3,  
6 2020, which, if approved by a two-thirds vote, authorizes the Fire District to establish a new  
7 appropriations limit for the next four years commencing in 2021-2022 fiscal year; and

8           **WHEREAS**, the County of Lake Registrar of Voters' Office canvassed the returns of the  
9 election and has certified to the Fire District the results are received, attached and made a part  
10 hereof as "Exhibit A."

11           **NOW, THEREFORE, BE IT RESOLVED** by the South Lake County Fire Protection District  
12 Board of Directors, that:

13           1. The ballot measure submitted to the electors and voted upon is as follows:

14                   "Shall South Lake County Fire Protection District, without increasing tax rate, establish  
15 annual appropriations limit in amount of \$1,250,000 plus special tax levy amount voters  
16 approved in Ordinance No. 2018-19-01 over and above previously approved  
17 appropriations limit, as annually adjusted pursuant to Article XIIB of the California State  
18 Constitution, which shall be effective fiscal year 2021-2022; and for three fiscal years  
19 thereafter said limit shall continue and be adjusted for changes in cost of living and  
20 population?"

21   YES\_\_\_           NO\_\_\_

22           2. The Final Official Results of Ballots Cast are Vote by Mail Total of 5,136 and Election  
23 Day Voting Total of 594 for Grand Total Ballots Cast of 5,900, as provided "Exhibit A."

24           3. The number of votes in favor and against Measure O is 3,771 Yes (or 68.8%) and 1,707  
25 No (or 31.2%), with Election Day Votes, for and against Measure O, including Vote by  
26 Mail, are given on the Statement of Votes in Exhibit A.

27 4. The Board of Directors declares and determines that results of the election, two thirds of  
28 voters voting on Measure O relating to the appropriations limit voted in favor, and that  
29 Measure O is thereby carried and hereby deemed adopted and ratified.

30 5. The Board Clerk shall attest the passage and adoption of this resolution and enter into  
31 records the resolution.

32 **THIS RESOLUTION** was introduced and adopted by the Board of Directors of the South  
33 Lake County Fire Protection District at a Regular Meeting on the 15<sup>th</sup> day of December, 2020  
34 by the following vote

AYES:

NOES:

ABSENT OR NOT VOTING:

SOUTH LAKE COUNTY  
FIRE PROTECTION DISTRICT

\_\_\_\_\_  
MADELYN MARTINELLI  
President, Board of Directors

ATTEST: \_\_\_\_\_  
Gloria Fong  
Clerk to the Board of Directors



**COUNTY OF LAKE**  
**Office of the Registrar**  
Courthouse - 255 North Forbes Street  
Lakeport, CA 95453  
Telephone 707/263-2372  
FAX 707/263-2742

**MARIA VALADEZ**  
**Registrar of Voters**  
**LOURDES PANTALEON**  
**Deputy Registrar of Voters**

**CERTIFICATION OF COUNTY ELECTIONS OFFICIAL OF RESULTS  
OF THE OFFICIAL CANVASS OF THE ELECTION RETURNS  
AND THE RESULTS OF THE 1% MANUAL TALLY OF  
RANDOMLY SELECTED VOTING PRECINCTS FOR THE  
NOVEMBER 3, 2020 GENERAL ELECTION**

**STATE OF CALIFORNIA)**

SS

**COUNTY OF LAKE)**

I, MARIA VALADEZ, Registrar of Voters, do hereby certify that, in pursuance of the provisions of Division 15, Chapter 4, Article 5 (commencing with Section 15360) of the Elections Code, State of California, I conducted the 1% public manual tally of randomly selected precincts for the November 3, 2020 General Election commencing on Tuesday, November 17, 2020 and ending on Thursday, November 19, 2020; and the following random voting precincts were selected for the 1% manual tally: VBM-382 (No Election Day votes cast at 382 Voting Precinct - only Provisional/Conditional ballots); 111 (VBM-111); 215 (VBM-215); 311 (VBM-311); VBM-411 (No Election Day votes cast at 411 Voting Precinct – only Provisional/Conditional ballots); and, 561 (VBM-561). The findings of the Canvassing Board, consisting of four (4) members, found that the Hart Verity Voting System tabulated the ballots correctly and the Canvassing Board did not find any discrepancies between the machine count and the manual tally; other than unintentional and explainable human error.

Following the completion of the 1% public manual tally and counting all of the remaining vote-by-mail ballots, approved office provisional/conditional ballots, and approved polls provisional/conditional ballots; I do hereby certify that, in pursuance of the provisions of Division 15, Chapter 4, Article 1 (commencing with Section 15300) of the Elections Code, I did canvass the returns of the votes cast for elective public offices, State propositions, and the local fire district measure; and, I do hereby certify that the Statement of Votes, to which this certification is attached, shows the total number of votes cast in each of the respective voting precincts therein, and that the totals of the respective columns and the totals as shown for each candidate, State propositions, and local fire district measure are full, true and correct.

WITNESS my hand and official seal this 1st day of December, 2020.



*Maria Valadez*  
\_\_\_\_\_  
MARIA VALADEZ, REGISTRAR OF VOTERS

South Lake County Fire Prot Distrct - Measure O

Cumulative Totals

Precinct	Registration	Ballots Cast	Turnout (%)	YES	NO
	111 MIDDLETOWN	690	572	82.9	353
112 CENTRAL PARK	469	368	78.5	201	126
113 HIDDEN VALLEY 1	936	807	86.2	540	215
114 HIDDEN VALLEY 2	776	578	74.5	398	146
115 HIDDEN VALLEY 3	867	757	87.3	485	208
116 HIDDEN VALLEY 4	978	803	82.1	495	250
117 HV RANCHOS	230	180	78.3	100	70
118 SPRUCE GROVE	167	142	85.0	93	37
119 JERUSALEM	30	24	80.0	20	3
120 COYOTE VALLEY	145	109	75.2	59	48
121 TWIN LAKES	11	16	145.5	3	2
123 PERINI HILL	6	6	100.0	6	0
561 LOCH LOMOND	463	382	82.5	235	125
571 GLENBROOK	501	426	85.0	286	116
581 W PINE/HOBERGS	881	730	82.9	497	177
<b>Vote by Mail Totals</b>	<b>7,150</b>	<b>5,136</b>	<b>71.8</b>	<b>3,395</b>	<b>1,412</b>
<b>Election Day Voting Totals</b>	<b>7,150</b>	<b>764</b>	<b>10.7</b>	<b>376</b>	<b>295</b>
<b>Grand Totals</b>	<b>7,150</b>	<b>5,900</b>	<b>82.5</b>	<b>3,771</b>	<b>1,707</b>



South Lake County Fire Prot District - Measure O

Vote by Mail  
Totals

District	Registration	Ballots Cast	Turnout (%)	YES	NO
Lake County	7,150	5,136	71.8	3,395	1,412
5th Congressional District	7,150	5,136	71.8	3,395	1,412
2nd Senatorial District	7,150	5,136	71.8	3,395	1,412
4th Assembly District	7,150	5,136	71.8	3,395	1,412
1st Supervisorial District	5,305	3,781	71.3	2,465	1,069
5th Supervisorial District	1,845	1,355	73.4	930	343
Bd Of Equalization, Dist 2	7,150	5,136	71.8	3,395	1,412
Unincorporated Area	7,150	5,136	71.8	3,395	1,412
<b>Vote by Mail Totals</b>	<b>7,150</b>	<b>5,136</b>	<b>71.8</b>	<b>3,395</b>	<b>1,412</b>

South Lake County Fire Prot Distrct - Measure O

Election Day  
Voting Totals

District	Registration	Ballots Cast	Turnout (%)	YES	NO
Lake County	7,150	764	10.7	376	295
5th Congressional District	7,150	764	10.7	376	295
2nd Senatorial District	7,150	764	10.7	376	295
4th Assembly District	7,150	764	10.7	376	295
1st Supervisorial District	5,305	581	11.0	288	220
5th Supervisorial District	1,845	183	9.9	88	75
Bd Of Equalization, Dist 2	7,150	764	10.7	376	295
Unincorporated Area	7,150	764	10.7	376	295
<b>Election Day Voting Totals</b>	<b>7,150</b>	<b>764</b>	<b>10.7</b>	<b>376</b>	<b>295</b>

South Lake County Fire Prot Distrct - Measure O

Grand Totals

District	Registration	Ballots Cast	Turnout (%)	YES	NO
Lake County	7,150	5,900	82.5	3771	1707
5th Congressional District	7,150	5,900	82.5	3771	1707
2nd Senatorial District	7,150	5,900	82.5	3771	1707
4th Assembly District	7,150	5,900	82.5	3771	1707
1st Supervisorial District	5,305	4,362	82.2	2753	1289
5th Supervisorial District	1,845	1,538	83.4	1018	418
Bd Of Equalization, Dist 2	7,150	5,900	82.5	3771	1707
Unincorporated Area	7,150	5,900	82.5	3771	1707
<b>Vote by Mail Totals</b>	7,150	5,136	71.8	3,395	1,412
<b>Election Day Voting Totals</b>	7,150	764	10.7	376	295
<b>Grand Totals</b>	7,150	5,900	82.5	3,771	1,707



**South Lake County Fire Protection District**  
in cooperation with  
**California Department of Forestry and Fire Protection**

P.O. Box 1360 Middletown, CA 95461 (707) 987-3089

**STAFF REPORT**

**To:** South Lake County Fire Protection District Board of Directors      **Date:** 12/05/2020

**From:** Chief Paul Duncan, Battalion Chief Mike Wink and PCF President Todd Fenk

**Re:** Use of ABH funds to make repairs to E6061

**EXECUTIVE SUMMARY**

In the Spring of 2020 the concept was approved to repurpose our 2003 Chevrolet Ambulance and make it into a Type 6 Fire Engine. This option was considered and approved to support our PCF responders. This will be a Class C vehicle that will provide transitional training and experience before responders are ready to operate larger Class B vehicles. Since 2015 South Lake County Fire Protections Districts 293 square miles has been damaged, destroyed and threatened by over a dozen major wildland fires. This type of vehicle would have been used on most if not all of those fires. This project was funded by the Fire Districts ABH Funds, the Volunteer Firefighters Association and the South lake Fire Sirens contributions.

**BACKGROUND**

The repurposing of E6061 was completed by Cascade Fire in Oregon this summer. A Team of PCFs went and picked it up. While they were driving home there was a engine fire that the PCFs put out. It caused damage to the firewall and some wiring harness's that made the vehicle not functional. The best option is to replace the damaged cab and chassis with a new one using the funds received from the insurance company.

**ANALYSIS**

This section would analyze the situation or issue from the current perspective and may include some or all of the following items:

**Environmental Impacts** – This will allow the quicker deployment of water on a fire which will reduce the amount of smoke and harmful byproducts of combustion to be produced.

**Fiscal Impacts** –

The ABH Funds will pay for the repair / upgrade of the cab and chassis. The current available balance of the ABH Funds that are used for Training, Current year ABH funds through end of July is attached. Prior years also included.

The Volunteers Firefighters Association will contribute at least \$5,000.00.

The Fire Sirens will contribute at least \$5,000.00.

The selling of the damaged cab and chassis funds will be used towards this purchase.

Use the Insurance funds of \$7,321 and Medic 6211 surplus sales funds of \$4,610 towards the purchase of the new cab and chassis.

### Pro and Cons

Pros- A new F550 cab and chassis will allow for a greater GVWR capabilities. The Volunteer Firefighters have offered to pay for the flat bed and four door cab up cost. This is important to the PCFs to add the additional seating and shorter wheelbase that they will pay for it so it will be cost neutral to the Fire District

Cons- The replacement of the damaged cab and chassis due to the engine compartment fire was not expected. We do have the funds available but they were not budgeted. Insurance does not cover the full cost because they want to fix the 2003 vehicle that we do not.

### ALTERNATIVES

1. Purchase a new for F550 4x4 cab and chassis long bed and put it back in service. \$112,945.80 (\$56,200 F550 bid packet summary recommendation plus \$56,745.80 Cascade invoice)
2. Purchase a new for F550 4x4 cab and chassis short bed, change the flat bed and put it back in service. The Volunteer Firefighters will cover the additional cost for the 4 door cab and shorter flatbed. It will not cost the Fire District anything additional. \$122,668.09 (CFE Pump Package quote amount of \$26,595.86 and Chassis Option quote amount plus \$56,745.80 Cascade invoice)
3. Try to sell all of the individual parts of the Type 6 build up. Sell the cab and chassis and any other accessories to recover funds and not have a Type 6.
4. Go to Oregon and bring the vehicle home on a trailer and then evaluate additional options to be determined.

### RECOMMENDATION

Alternative 2 is recommended by the Chiefs and the Volunteer Firefighters Association. The amount on the attached resolution is blank and, if approved, requires amount be stated in motion.



**CASCADE FIRE  
EQUIPMENT COMPANY**

P.O. BOX 4248 • MEDFORD, OREGON 97501  
(800) 654-7049 • (541) 779-0394 • Fax (541) 779-8847  
[sales@cascadefire.com](mailto:sales@cascadefire.com) • [www.cascadefire.com](http://www.cascadefire.com)

# INVOICE

ACCOUNT 0000908

SOLD TO SOUTH LAKE COUNTY F. P. D.  
PO BOX 1360

MIDDLETOWN CA 95461-

SHIP TO SOUTH LAKE COUNTY F. P. D.  
21095 HWY 175

MIDDLETOWN CA 95461-

ORDER DATE	SHIP DATE	ORDER NO.	SALESPERSON	TAKEN BY	SHIP VIA	PAY TYPE	CUST P.O.
04/29/20	09/17/20	097483	1	Matt	WILL CALL	Net 30	MIKE WINK

LINE	ORD QTY	SHIP QTY	BO QTY	UNIT	PROD	DESCRIPTION	UNIT PRICE	EXT PRICE
1	1	1	0	EA	24121	150 GALLON END MOUNT UNIT, JOB# 867 18 HP BRIGGS W/ CF-120 PUMP 2.5" HYD FILL ALUM REEL W/ 1"X100' REELTEX FLATBED BOXES TANK BASKET BASKET ON HOSE TRAY	43144.84	43144.84
9	2	2	0	EA	SPA530-R-14-ON-BOB-CL-ST-A	SPECTRA MS, 14K LM 12V SIDE MOUNT, LED LIGHT	1860.00	3720.00
10	4	4	0	EA	12001	BRACKET, DRIP TORCH	50.00	200.00
11	2	2	0	EA	21229	BRACKET, CHOCK MEDIUM UNDERBODY	35.00	70.00
12	2	2	0	EA	21216	CHOCK, MEDIUM DUTY, ALUMINUM	42.00	84.00
13	3	3	0	EA	11564-8	HOSE, PVC SUCTION 2X8 CPLD NPSH	86.00	258.00
						HOSE FOR HOSE STORAGE COMPARTMENTS		
17	1	1	0	EA	23953	FOOT VALVE & STRAINER 2"	125.00	125.00



**CASCADE FIRE  
EQUIPMENT COMPANY**

P.O. BOX 4248 • MEDFORD, OREGON 97501  
(800) 654-7049 • (541) 779-0394 • Fax (541) 779-8847  
[sales@cascadefire.com](mailto:sales@cascadefire.com) • [www.cascadefire.com](http://www.cascadefire.com)

20	3	3	0	EA	50312	FED HOSE PACK	65.00	195.00
21	8	8	0	EA	40251	McLEOD TOOL	89.00	712.00
22	6	6	0	EA	40258	PULASKI TOOL	75.00	450.00



**CASCADE FIRE  
EQUIPMENT COMPANY**

P.O. BOX 4248 • MEDFORD, OREGON 97501  
 (800) 654-7049 • (541) 779-0394 • Fax (541) 779-8847  
[sales@cascadefire.com](mailto:sales@cascadefire.com) • [www.cascadefire.com](http://www.cascadefire.com)

LINE	ORD QTY	SHIP QTY	BO QTY	UNIT	PROD	DESCRIPTION	UNIT PRICE	EXT PRICE
23	5	5	0	EA	50333	CHAPS, ORANGE 32" NFPA	174.00	870.00
24	2	2	0	EA	24180	BACK-PACK 5 GAL. SMOKECHASE	155.00	310.00
25	2	2	0	EA	20905	FIRE EXT, ABC - 20 LB	185.00	370.00
26	5	5	0	EA	10921NPSH	NOZZLE,RANGER 1"NPSH 10-30GPM	95.00	475.00
27	6	6	0	EA	10902	NOZZLE, RANGER 1½" NH	110.00	660.00
28	5	5	0	EA	11000NPSH	DBL MALE 1NPSH X 1NPSH L/W	40.00	200.00
29	5	5	0	EA	11010NPSH	ADAPTER DBL FEMALE, 1" X 1" NPSH	32.00	160.00
30	5	5	0	EA	11001NH	DBL MALE 1.5NH X 1.5NH L/W	25.00	125.00
31	5	5	0	EA	11011NH	ADAPTER DBL FEMALE, 1.5" X 1.5" NH	28.00	140.00
32	1	1	0	EA	40711	BALL SHUTOFF 1.5"	120.00	120.00
33	1	1	0	EA	40069NH	NO SNAG WYE, 1.5" NH X (2) 1.5" NH	195.00	195.00
34	2	2	0	EA	11213	HOSE CLAMP, 1.5"	65.00	130.00
35	1	1	0	EA	10313	HYDRANT WRENCH, CASCADE	60.00	60.00
36	2	2	0	EA	11039NPSH	REDUCER, 1.5" NH (F) X 1" NPSH (M) R/L	24.00	48.00
37	4	4	0	EA	10320	UNIVERSAL SPANNER, CASCADE	22.00	88.00

TOTAL FREIGHT	TOTAL MISC	TOTAL TAX	TOTAL
0.00	0.00	3835.96	56745.80



# F550 Bid Packet Summary

All prices are the similar specifications and don't include tax/registration.  
The vehicle would be drop-shipped to Cascade Fire Equipment in Medford, OR

### XL Trim Level

Corning Ford	\$ 53,900.00	\$ 669.00
Redwood Ford	<b>\$ 53,231.00</b>	Lowest
Hansel Ford	\$ 58,089.04	\$ 4,858.04

### XLT Trim Level

Corning Ford	<b>\$ 56,200.00</b>	Lowest
Redwood Ford	\$ 57,750.00	\$ 1,550.00
Hansel Ford	\$ 62,491.65	\$ 6,291.65

### Lariat Trim Level

Corning Ford	\$ 59,974.00	\$ 976.00
Redwood Ford	<b>\$ 58,998.00</b>	Lowest
Hansel Ford	\$ 65,323.05	\$ 6,325.05

Difference in trim levels:

XL - Base Trim - No navigation

XLT - Mid-Level - Has navigation option and better trim items

Lariat - Top Trim - Navigation standard, but has leather

**\*Recommendation\***  
XLT Trim with navigation option from Corning Ford

Prepared for: Paul Duncan, SLCFPD  
21095 Hwy 175  
Middletown, CA 95461

---

2021 F-550 Chassis 4x4 SD Crew Cab 203" WB DRW XL (W5H)

Price Level: 115

---



**Client Proposal**

Prepared by:  
Joe Gazdowicz  
Office: 707-543-7351  
Email: [jgazdowicz@hanselauto.com](mailto:jgazdowicz@hanselauto.com)  
Quote ID: SLCFD  
Date: 10/12/2020

Hansel Ford



Prepared for: Paul Duncan

"Alternative 1"



SLCFPD

Prepared by: Joe Gazdowicz

10/12/2020

Hansel Ford | 3075 Corby Ave Santa Rosa California | 954077879

2021 F-550 Chassis 4x4 SD Crew Cab 203" WB DRW XL (W5H)

Price Level: 115 | Quote ID: SLCFD

## Pricing Summary - Single Vehicle

	<b>MSRP</b>
<i>Vehicle Pricing</i>	\$65,720.00
<i>Pre-Tax Adjustments</i>	
<b>Description</b>	
Government Discount	-\$11,595.00
<b>Subtotal</b>	<b>\$54,125.00</b>
<i>Sales Taxes</i>	
<b>Description</b>	
7.25	\$3,923.54
<b>Subtotal</b>	<b>\$58,048.54</b>
<i>Post-Tax Adjustments</i>	
<b>Description</b>	
CA Tire Fee 6 tires	\$10.50
Electronic Title Fee	\$30.00
<b>Total</b>	<b>\$58,089.04</b>

\_\_\_\_\_  
Customer Signature

\_\_\_\_\_  
Acceptance Date

# Hansel Ford

Prices and content availability as shown are subject to change and should be treated as estimates only. Actual base vehicle, package and option pricing may vary from this estimate because of special local pricing, availability or pricing adjustments not reflected in the dealer's computer system. See salesperson for the most current information.

CNGP530

VEHICLE ORDER CONFIRMATION

10/12/20 17:13:51

==>

Dealer: F72438

2021 F-SERIES SD

Page: 1 of 3

Order No: 2323 Priority: A1 Ord FIN: QX393 Order Type: 5B Price Level: 115

Ord PEP: 660A Cust/Flt Name: SLCFPD PO Number:

RETAIL

RETAIL

W5H	F550 4X4 CRW CC	\$47720		FLEET SPCL ADJ	NC
	203" WHEELBASE			FRT LICENSE BKT	NC
E4	VERMILLION RED	660	17F	XL DECOR PKG	NC
L	40/CNSL/40 VNYL	355	18A	UPFIT INTER MOD	295
S	MEDIUM EARTH GR			TPMS DELETE	
660A	PREF EQUIP PKG			19500# GVWR PKG	
	.XL TRIM		41P	SKID PLATES	100
572	.AIR CONDITIONER	NC	425	50 STATE EMISS	NC
	.AMFM/MP3/CLK				
99T	6.7L V8 DIESEL	9325		TOTAL BASE AND OPTIONS	66620
44G	10-SPD AUTOMATC	NC		TOTAL	66620
TGJ	225 BSW AP 19.5			*THIS IS NOT AN INVOICE*	
X8L	4.88 LTD SLIP	360			
90L	PWR EQUIP GROUP	1075		* MORE ORDER INFO NEXT PAGE *	
54K	TELE TT MIR-PWR	NC		F8=Next	

F1=Help                      F2=Return to Order                      F3/F12=Veh Ord Menu  
 F4=Submit                  F5=Add to Library

S006 - MORE DATA IS AVAILABLE.

QC05307

V1DP0335

2,6

*Your PRICE + \$3,231 + FEES.*

Redwood Ford

CNGP530

VEHICLE ORDER CONFIRMATION

10/12/20 17:13:59

==>

Dealer: F72438

2021 F-SERIES SD

Page: 2 of 3

Order No: 2323 Priority: A1 Ord FIN: QX393 Order Type: 5B Price Level: 115

Ord PEP: 660A Cust/Flt Name: SLCFPD PO Number:

RETAIL

RETAIL

43B	BACKGLASS DEF	NC	924	PRIVACY GLASS	\$30
435	PWR SLD RR WNDW	405	96V	XL VALUE PKG	395
52B	BRAKE CONTROLR	270		.CRUISE CONTROL	
535	HI CAP TRLR TOW	580	98R	OPRTR COMND REG	250
59H	HI MNT STOP LMP	NC		SP DLR ACCT ADJ	
61J	JACK	55		SP FLT ACCT CR	
61L	WHL WLL LNR FRT	180		FUEL CHARGE	
62R	TRANS PTO PROV	NC	B4A	NET INV FLT OPT	NC
63A	UTLTY LIGHT SYS	160			
65C	DUAL FUEL TANKS	625		TOTAL BASE AND OPTIONS	66620
67X	XTR HS SUSPEN	125		TOTAL	66620
68M	PAYLD PLUS UPGR	1155		*THIS IS NOT AN INVOICE*	
76C	EX BACKUP ALARM	140			
86A	ENG IDL SHUT 5	250		* MORE ORDER INFO NEXT PAGE *	
872	RR CAM & PREP K	415		F7=Prev	F8=Next

F1=Help F2=Return to Order F3/F12=Veh Ord Menu

F4=Submit F5=Add to Library

S006 - MORE DATA IS AVAILABLE.

QC05307

CNGP530

VEHICLE ORDER CONFIRMATION

10/12/20 17:14:14

==>

Dealer: F72438

2021 F-SERIES SD

Page: 3 of 3

Order No: 2323 Priority: A1 Ord FIN: QX393 Order Type: 5B Price Level: 115

Ord PEP: 660A Cust/Flt Name: SLCFPD PO Number:

RETAIL

RETAIL

DEST AND DELIV \$1695

TOTAL BASE AND OPTIONS 66620

TOTAL 66620

\*THIS IS NOT AN INVOICE\*

F7=Prev

F1=Help

F2=Return to Order

F3/F12=Veh Ord Menu

F4=Submit

F5=Add to Library

S099 - PRESS F4 TO SUBMIT

QC05307

XLT

\$ 56,200 + TAX

"Alternative 1"

VIRTC1DP VA.58 5432 EN

CNGP530 VEHICLE ORDER CONFIRMATION 10/09/20 12:38:42  
==> Dealer: F72523

2021 F-SERIES SD

Page: 1 of 2

Order No: 1234 Priority: A1 Ord FIN: QB494 Order Type: 5B Price Level: 115

Ord PEP: 663A Cust/Flt Name: LAKEFIRE XLT PO Number:

RETAIL

RETAIL

W5H	F550 4X4 CRW CC	\$52275	TPMS DELETE	
	203" WHEELBASE		19500# GVWR PKG	
PQ	RACE RED		41P SKID PLATES	100
3	40/20/40 CLOTH		425 50 STATE EMISS	NC
S	MEDIUM EARTH GR		43B BACKGLASS DEF	NC
663A	PREF EQUIP PKG		435 PWR SLD RR WNDW	405
	.XLT TRIM		535 HI CAP TRLR TOW	580
	.AMFM/MP3/CLK		61J JACK	55
99T	6.7L V8 DIESEL	9325		
44G	10-SPD AUTOMATC	NC	TOTAL BASE AND OPTIONS	68390
TGJ	225 BSW AP 19.5		TOTAL	68390
X8L	4.88 LTD SLIP	360	*THIS IS NOT AN INVOICE*	
	FLEET SPCL ADJ	NC	* MORE ORDER INFO NEXT PAGE *	
	FRT LICENSE BKT	NC	F8=Next	
18A	UPFIT INTER MOD	295	F3/F12=Veh Ord Menu	

F1=Help F2=Return to Order F3/F12=Veh Ord Menu  
F4=Submit F5=Add to Library

VIRTC1DP VA.58 5432 EN

CNGP530 VEHICLE ORDER CONFIRMATION 10/09/20 12:39:05  
==> Dealer: F72523

2021 F-SERIES SD

Page: 2 of 2

Order No: 1234 Priority: A1 Ord FIN: QB494 Order Type: 5B Price Level: 115

Ord PEP: 663A Cust/Flt Name: LAKEFIRE PO Number:

RETAIL

RETAIL

61L	WHL WLL LNR FRT	\$180	PRICED DORA	NC
62R	TRANS PTO PROV	NC	DEST AND DELIV	1695
63A	UTLTY LIGHT SYS	160		
65C	DUAL FUEL TANKS	625	TOTAL BASE AND OPTIONS	68390
67A	332 AMP ALTRNTR	NC	TOTAL	68390
67X	XTR HS SUSPEN	125	*THIS IS NOT AN INVOICE*	
68M	PAYLD PLUS UPGR	1155		
76C	EX BACKUP ALARM	140		
86A	ENG IDL SHUT 5	250		
872	RR CAM & PREP K	415		
98R	OPRTR COMND REG	250		
	SP DLR ACCT ADJ			
	SP FLT ACCT CR			
	FUEL CHARGE			
B4A	NET INV FLT OPT	NC	F7=Prev	

F1=Help F2=Return to Order F3/F12=Veh Ord Menu  
F4=Submit F5=Add to Library

S099 - PRESS F4 TO SUBMIT

QC077751

Corning Ford XLT

V1DP0174

2,6

- XL - 53,900<sup>00</sup> + TAX -

"Alternative 1"

VIRTC1DP V4.58 5432 EN

CNGP530 VEHICLE ORDER CONFIRMATION 10/09/20 12:44:23  
==> Dealer: F72523

2021 F-SERIES SD

Page: 1 of 3

Order No: 1234 Priority: A1 Ord FIN: QB494 Order Type: 5B Price Level: 115  
Ord Code: 660A Cust/Flt Name: LAKEFIRE XL PO Number:

RETAIL

RETAIL

W5H	F550 4X4 CRW CC	\$47720	FLEET SPCL ADJ	NC
	203" WHEELBASE		FRT LICENSE BKT	NC
PQ	RACE RED		17F XL DECOR PKG	NC
A	VNYL 40/20/40		18A UPFIT INTER MOD	295
S	MEDIUM EARTH GR		TPMS DELETE	
660A	PREF EQUIP PKG		19500# GVWR PKG	
	.XL TRIM		41P SKID PLATES	100
572	.AIR CONDITIONER	NC	425 50 STATE EMISS	NC
	.AMFM/MP3/CLK			
99T	6.7L V8 DIESEL	9325	TOTAL BASE AND OPTIONS	65780
44G	10-SPD AUTOMATC	NC	TOTAL	65780
TGJ	225 BSW AP 19.5		*THIS IS NOT AN INVOICE*	
X8L	4.88 LTD SLIP	360		
90L	PWR EQUIP GROUP	1075	* MORE ORDER INFO NEXT PAGE *	
54K	TELE TT MIR-PWR	NC	F8=Next	
F1=Help	F2=Return to Order		F3/F12=Veh Ord Menu	
F4=Submit	F5=Add to Library			

VIRTC1DP V4.58 5432 EN

CNGP530 VEHICLE ORDER CONFIRMATION 10/09/20 12:44:45  
==> Dealer: F72523

2021 F-SERIES SD

Page: 2 of 3

Order No: 1234 Priority: A1 Ord FIN: QB494 Order Type: 5B Price Level: 115  
Ord Code: 660A Cust/Flt Name: LAKEFIRE XL PO Number:

RETAIL

RETAIL

43B	BACKGLASS DEF	NC	872	RR CAM & PREP K	\$415
43C	110V/400W OUTLT	175	924	PRIVACY GLASS	30
435	PWR SLD RR WNDW	405	96V	XL VALUE PKG	395
52B	BRAKE CONTROLLR	270		.CRUISE CONTROL	
535	HI CAP TRLR TOW	580	98R	OPRTR COMND REG	250
61J	JACK	55		SP DLR ACCT ADJ	
61L	WHL WLL LNR FRT	180		SP FLT ACCT CR	
62R	TRANS PTO PROV	NC		FUEL CHARGE	
63A	UTLTY LIGHT SYS	160			
65C	DUAL FUEL TANKS	625	TOTAL	BASE AND OPTIONS	65780
67A	332 AMP ALTRNTR	NC	TOTAL		65780
67X	XTR HS SUSPEN	125	*THIS IS NOT AN INVOICE*		
68M	PAYLD PLUS UPGR	1155			
76C	EX BACKUP ALARM	140	* MORE ORDER INFO NEXT PAGE *		
86A	ENG IDL SHUT 5	250	F7=Prev F8=Next		
F1=Help	F2=Return to Order		F3/F12=Veh Ord Menu		
F4=Submit	F5=Add to Library				

S006 - MORE DATA IS AVAILABLE.

QC077751

Corning Ford - XL

V1DP0174

2,6



Prepared for: Paul Duncan

"Alternative 1"



SLCFPD

Prepared by: Joe Gazdowicz

10/12/2020

Hansel Ford | 3075 Corby Ave Santa Rosa California | 954077879

2021 F-550 Chassis 4x4 SD Crew Cab 203" WB DRW XLT (W5H)

Price Level: 115 | Quote ID: SLFDXLTF55

## Pricing Summary - Single Vehicle

	<b>MSRP</b>
<i>Vehicle Pricing</i>	\$70,230.00
<i>Pre-Tax Adjustments</i>	
<b>Description</b>	
Government Discount	-\$12,000.00
<b>Subtotal</b>	<b>\$58,230.00</b>
<i>Sales Taxes</i>	
<b>Description</b>	
7.25	\$4,221.15
<b>Subtotal</b>	<b>\$62,451.15</b>
<i>Post-Tax Adjustments</i>	
<b>Description</b>	
CA Tire Fee 6 tires	\$10.50
Electronic Title Fee	\$30.00
<b>Total</b>	<b>\$62,491.65</b>

\_\_\_\_\_  
Customer Signature

\_\_\_\_\_  
Acceptance Date

Prices and content availability as shown are subject to change and should be treated as estimates only. Actual base vehicle, package and option pricing may vary from this estimate because of special local pricing, availability or pricing adjustments not reflected in the dealer's computer system. See salesperson for the most current information.

CNGP530

VEHICLE ORDER CONFIRMATION

10/12/20 17:37:23

==>

Dealer: F72438

2021 F-SERIES SD

Page: 1 of 2

Order No: 2323 Priority: A1 Ord FIN: QX393 Order Type: 5B Price Level: 115

Ord PEP: 663A Cust/Flt Name: SLCFPD PO Number:

RETAIL

RETAIL

W5H F550 4X4 CRW CC \$52275

18A UPFIT INTER MOD \$295

203" WHEELBASE

TPMS DELETE

E4 VERMILLION RED 660

19500# GVWR PKG

2 CLTH 40/CNSL/40 945

21N NAVIGATION SYS 570

S MEDIUM EARTH GR

39D HD SAT DIGITAL NC

663A PREF EQUIP PKG

41P SKID PLATES 100

.XLT TRIM

425 50 STATE EMISS NC

.AMFM/MP3/CLK

43B BACKGLASS DEF NC

99T 6.7L V8 DIESEL 9325

44G 10-SPD AUTOMATC NC

TOTAL BASE AND OPTIONS 71730

TGJ 225 BSW AP 19.5

TOTAL 71730

X8L 4.88 LTD SLIP 360

\*THIS IS NOT AN INVOICE\*

FLEET SPCL ADJ NC

\* MORE ORDER INFO NEXT PAGE \*

FRT LICENSE BKT NC

166 CARPET DELETE (50)

F8=Next

F1=Help

F2=Return to Order

F3/F12=Veh Ord Menu

F4=Submit F5=Add to Library

S006 - MORE DATA IS AVAILABLE.

QC05307

*Your Price*

V1DP0335

2,6

*\$57,750*

*+ Fees.*

Redwood Ford

CNGP530  
==>

VEHICLE ORDER CONFIRMATION

10/12/20 17:38:18

Dealer: F72438

2021 F-SERIES SD

Page: 2 of 2

Order No: 2323 Priority: A1 Ord FIN: QX393 Order Type: 5B Price Level: 115  
Ord PEP: 663A Cust/Flt Name: SLCFPD PO Number:

RETAIL

RETAIL

435 PWR SLD RR WNDW \$405  
535 HI CAP TRLR TOW 580  
54F PWRSCOPE TT MIR 280  
59H HI MNT STOP LMP NC  
61J JACK 55  
61L WHL WLL LNR FRT 180  
62R TRANS PTO PROV NC  
63A UTLTY LIGHT SYS NC  
64D POL ALNM WHLS 1095  
65C DUAL FUEL TANKS 625  
67A 332 AMP ALTRNTR NC  
67X XTR HS SUSPEN 125  
68M PAYLD PLUS UPGR 1155  
76C EX BACKUP ALARM 140  
86A ENG IDL SHUT 5 250

872 RR CAM & PREP K \$415  
98R OPRTR COMND REG 250  
SP DLR ACCT ADJ  
SP FLT ACCT CR  
FUEL CHARGE  
B4A NET INV FLT OPT NC  
DEST AND DELIV 1695

TOTAL BASE AND OPTIONS 71730

TOTAL 71730

\*THIS IS NOT AN INVOICE\*

F7=Prev

F1=Help F2=Return to Order

F3/F12=Veh Ord Menu

F4=Submit F5=Add to Library

S099 - PRESS F4 TO SUBMIT

QC05307

Prepared for: Paul Duncan

"Alternative 1"



SLCFPD

Prepared by: Joe Gazdowicz

10/12/2020

Hansel Ford | 3075 Corby Ave Santa Rosa California | 954077879

2021 F-550 Chassis 4x4 SD Crew Cab 203" WB DRW Lariat (W5H)

Price Level: 115 | Quote ID: SLCFDLARIA

## Pricing Summary - Single Vehicle

	<b>MSRP</b>
<i>Vehicle Pricing</i>	\$72,870.00
<i>Pre-Tax Adjustments</i>	
<b>Description</b>	
Government Discount	-\$12,000.00
<b>Subtotal</b>	<b>\$60,870.00</b>
<i>Sales Taxes</i>	
<b>Description</b>	
7.25	\$4,412.55
<b>Subtotal</b>	<b>\$65,282.55</b>
<i>Post-Tax Adjustments</i>	
<b>Description</b>	
CA Tire Fee 6 tires	\$10.50
Electronic Title Fee	\$30.00
<b>Total</b>	<b>\$65,323.05</b>

\_\_\_\_\_  
Customer Signature

\_\_\_\_\_  
Acceptance Date

Prices and content availability as shown are subject to change and should be treated as estimates only. Actual base vehicle, package and option pricing may vary from this estimate because of special local pricing, availability or pricing adjustments not reflected in the dealer's computer system. See salesperson for the most current information.

F550 crew cab



"LARIAT"

"Alternative 1"

VIRTCIDP 9418 5432 EN

CNGP530

VEHICLE ORDER CONFIRMATION

10/14/20 14:02:

==>

Dealer: F725

2021 F-SERIES SD

Page: 1 of

Order No: 1999 Priority: A2 Ord FIN: QY186 Order Type: 5B Price Level: 1

Ord PEP: 668A Cust/Flt Name: CAL FIRE PO Number:

RETAIL

RETAIL

W5H F550 4X4 CRW CC \$58065  
203" WHEELBASE

18A UPFIT INTER MOD \$295  
TPMS DELETE

PQ RACE RED

19500# GVWR PKG

6 LTHR 40/20/40

41P SKID PLATES 100

A MED LIGHT CAMEL

425 50 STATE EMISS NC

668A PREF EQUIP PKG

512 SPARE TIRE/WHL2 350

.LARIAT TRIM

535 HI CAP TRLR TOW 580

.B&O SOUND SYSTM

61J JACK NC

99T 6.7L V8 DIESEL 9325

44G 10-SPD AUTOMATC NC

TOTAL BASE AND OPTIONS 72735

TGJ 225 BSW AP 19.5

TOTAL 72735

X8L 4.88 LTD SLIP 360

\*THIS IS NOT AN INVOICE\*

FLEET SPCL ADJ NC

\* MORE ORDER INFO NEXT PAGE \*

FRT LICENSE BKT NC

166 CARPET DELETE (50)

F8=Next

VIRTCIDP 9418 5432 EN

CNGP530

VEHICLE ORDER CONFIRMATION

10/14/20 14:02:

==>

Dealer: F725

2021 F-SERIES SD

Page: 2 of

Order No: 1999 Priority: A2 Ord FIN: QY186 Order Type: 5B Price Level: 1

Ord PEP: 668A Cust/Flt Name: CAL FIRE PO Number:

RETAIL

RETAIL

61L WHL WLL LNR FRT \$180

TOTAL \$72735

62R TRANS PTO PROV NC

\*THIS IS NOT AN INVOICE\*

67A 332 AMP ALTRNTR NC

67X XTR HS SUSPEN 125

68M PAYLD PLUS UPGR 1155

76C EX BACKUP ALARM 140

872 RR CAM & PREP K 415

SP DLR ACCT ADJ

SP FLT ACCT CR

FUEL CHARGE

B4A NET INV FLT OPT NC

PRICED DORA NC

DEST AND DELIV 1695

Handwritten circled text: \$59,974.00 + TAX

TOTAL BASE AND OPTIONS 72735

F7=Prev

F1=Help

F2=Return to Order

F3/F12=Veh Ord Menu

F4=Submit F5=Add to Library

S099 - PRESS F4 TO SUBMIT

QC07775

CNGP530

VEHICLE ORDER CONFIRMATION

10/12/20 17:47:41

==>

Dealer: F72438

2021 F-SERIES SD

Page: 1 of 2

Order No: 2323 Priority: A1 Ord FIN: QX393 Order Type: 5B Price Level: 115

Ord PEP: 668A Cust/Flt Name: SLCFPD PO Number:

RETAIL

RETAIL

W5H F550 4X4 CRW CC \$58065

18A UPFIT INTER MOD \$295

203" WHEELBASE

TPMS DELETE

PQ RACE RED

19500# GVWR PKG

5 LTHR 40/CNSL/40 NC

21N NAVIGATION SYS 570

B BLACK

39D HD SAT DIGITAL NC

668A PREF EQUIP PKG

41P SKID PLATES 100

.LARIAT TRIM

425 50 STATE EMISS NC

.B&O SOUND SYSTM

535 HI CAP TRLR TOW 580

99T 6.7L V8 DIESEL 9325

44G 10-SPD AUTOMATC NC

TOTAL BASE AND OPTIONS 73010

TGJ 225 BSW AP 19.5

TOTAL 73010

X8L 4.88 LTD SLIP 360

\*THIS IS NOT AN INVOICE\*

FLEET SPCL ADJ NC

\* MORE ORDER INFO NEXT PAGE \*

FRT LICENSE BKT NC

166 CARPET DELETE (50)

F8=Next

F1=Help

F2=Return to Order

F3/F12=Veh Ord Menu

F4=Submit F5=Add to Library

S006 - MORE DATA IS AVAILABLE.

QC05307

Your Price

V1DP0335

2,6

+ 58,998

+ Fees.

Redwood Ford Lariat

CNGP530

VEHICLE ORDER CONFIRMATION

10/12/20 17:47:55

==>

Dealer: F72438

2021 F-SERIES SD

Page: 2 of 2

Order No: 2323 Priority: A1 Ord FIN: QX393 Order Type: 5B Price Level: 115

Ord PEP: 668A Cust/Flt Name: SLCFPD PO Number:

RETAIL

RETAIL

59H HI MNT STOP LMP NC

TOTAL BASE AND OPTIONS\$73010

61J JACK 55

TOTAL 73010

61L WHL WLL LNR FRT 180

\*THIS IS NOT AN INVOICE\*

62R TRANS PTO PROV NC

67A 332 AMP ALTRNTR NC

67X XTR HS SUSPEN 125

68M PAYLD PLUS UPGR 1155

76C EX BACKUP ALARM 140

872 RR CAM & PREP K 415

SP DLR ACCT ADJ

SP FLT ACCT CR

FUEL CHARGE

B4A NET INV FLT OPT NC

DEST AND DELIV 1695

F7=Prev

F1=Help

F2=Return to Order

F3/F12=Veh Ord Menu

F4=Submit

F5=Add to Library

S099 - PRESS F4 TO SUBMIT

QC05307

V1DP0335

2,6

**"Alternative 2"**

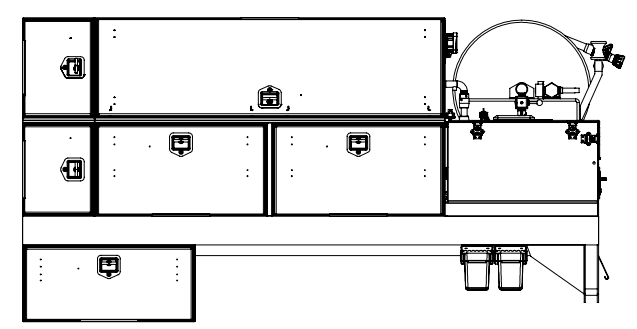
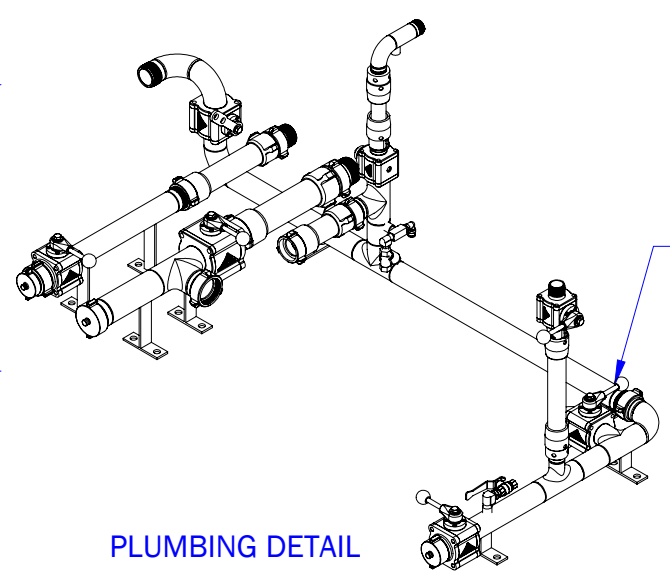
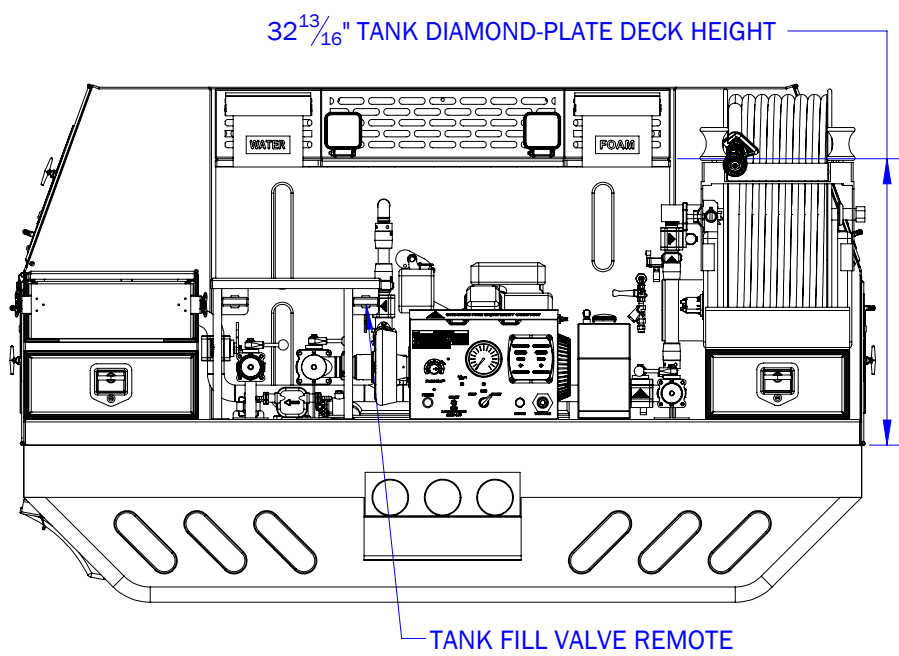
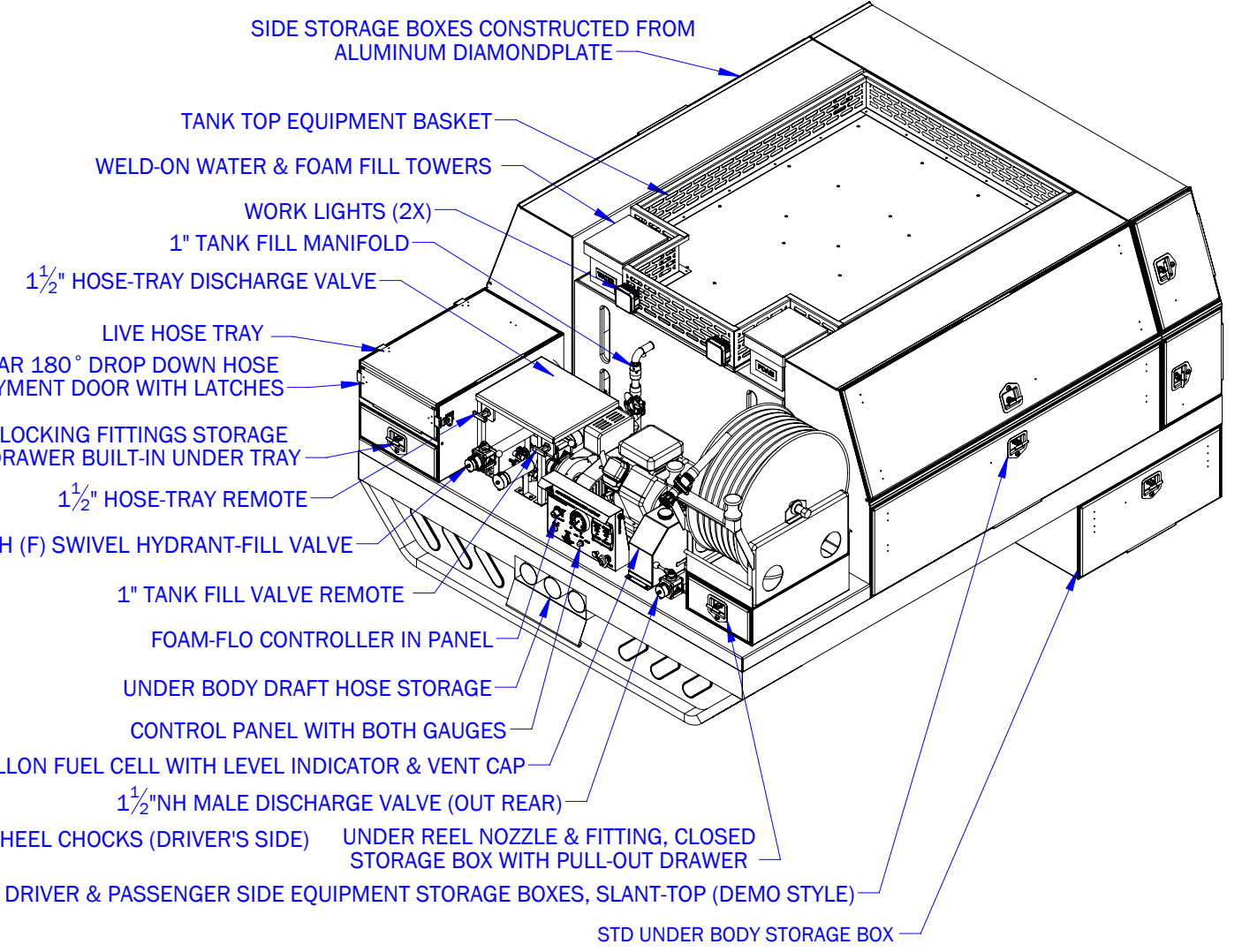
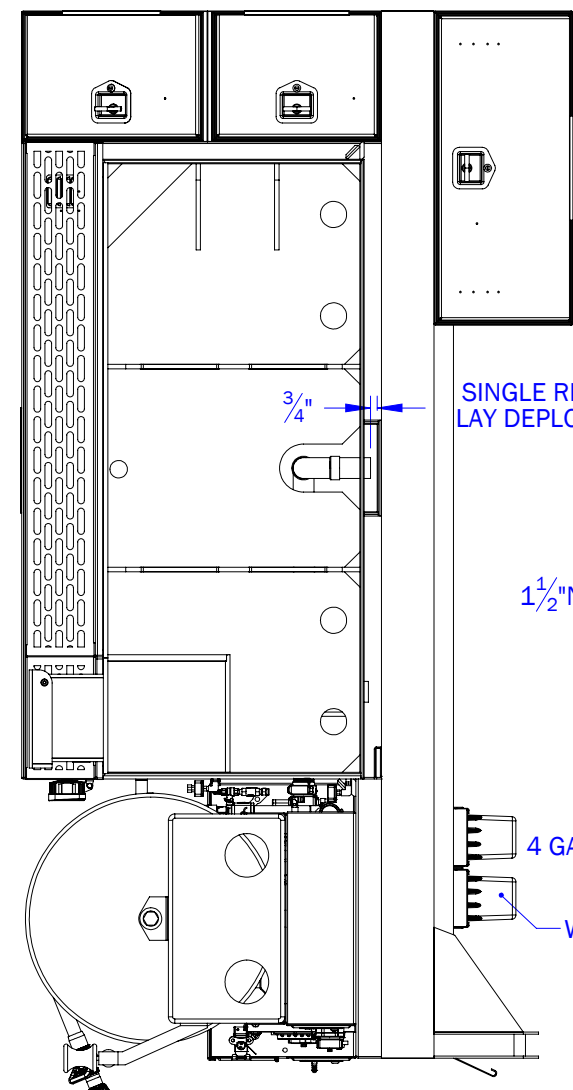
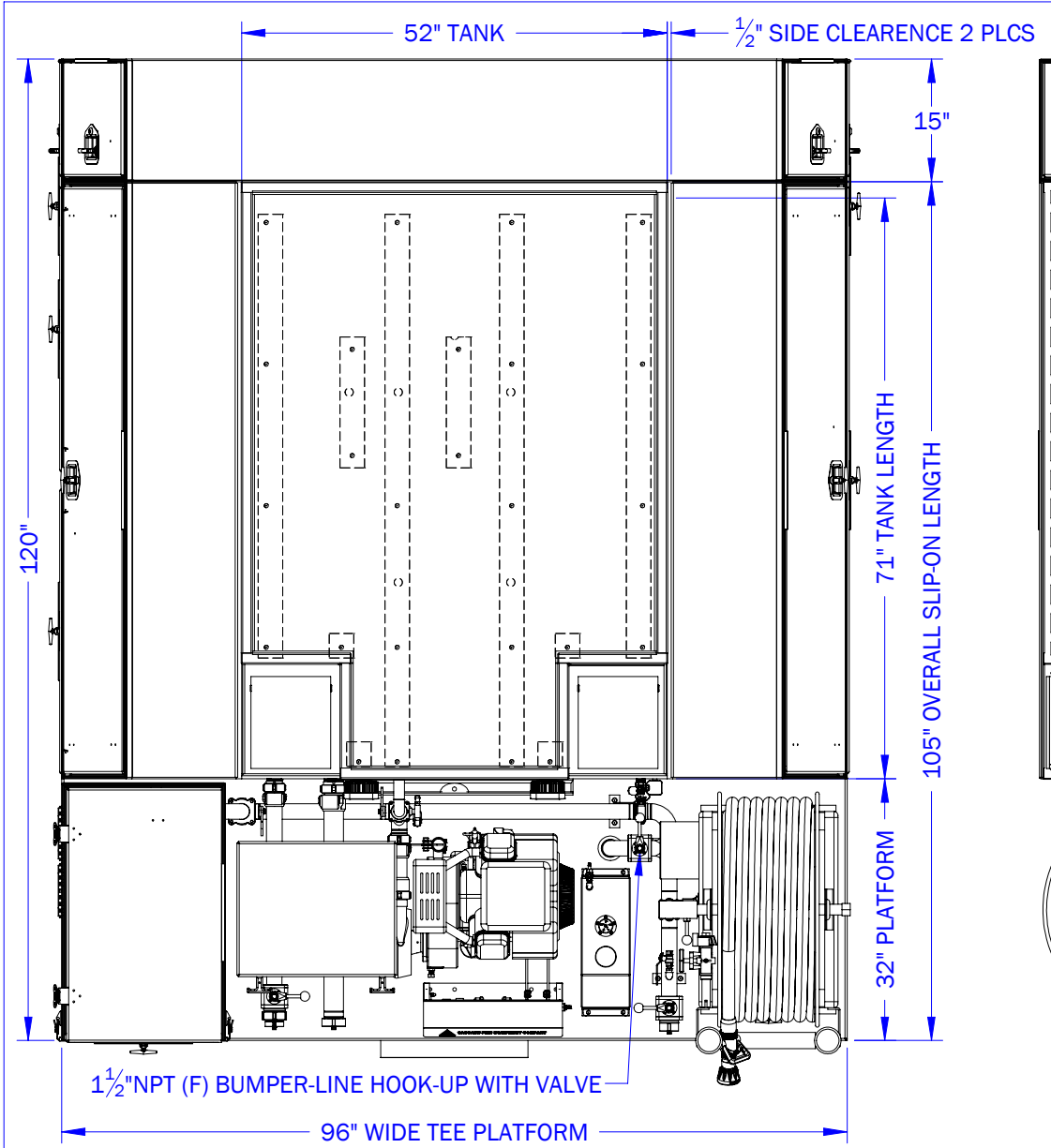

POLYPROPYLENE TANK:  
52" W x 71" L x 29 7/8" H  
WATER: 400 GALLONS  
FOAM: 10 GALLON CELL

PUMPER SYSTEM:  
FOAM SYSTEM: FOAM-FLO  
MOTOR: 18 HP VANGUARD  
PUMP: CASCADE CF-120  
REEL: HANNAY 20-30-31 ALUMINUM  
1/3 HP ELECTRIC REWIND MOTOR  
HOSE: 200' x 3/4" 300PSI  
THREADS: NH

THE INFORMATION CONTAINED IN THIS DRAWING IS THE SOLE PROPERTY OF CASCADE FIRE EQUIPMENT COMPANY. ANY REPRODUCTION IN PART OR AS A WHOLE WITHOUT THE WRITTEN PERMISSION OF CASCADE FIRE EQUIPMENT COMPANY IS PROHIBITED.



CASCADE FIRE EQUIPMENT COMPANY  
P.O. BOX 4248 MEDFORD, OR. 97501-  
CFE STANDARD PACKAGE A

**400 GALLON SKID UNIT**

DRAWN BY: L. MOLLMAN	SOLD BY:	REV. A
JOB: #	DATE: 9/26/2019	





**CASCADE FIRE  
EQUIPMENT COMPANY**

P.O. BOX 4248 • MEDFORD, OREGON 97501  
(800) 654-7049 • (541) 779-0394 • Fax (541) 779-8847  
[sales@cascadefire.com](mailto:sales@cascadefire.com) • [www.cascadefire.com](http://www.cascadefire.com)

**QUOTE**

ACCOUNT 0000908

SHIP TO SOUTH LAKE COUNTY F. P. D.  
PO BOX 1360  
MIDDLETOWN CA

DATE	QUOTE NO.	SALESPERSON	TAKEN BY	PAY TYPE
10/16/20	102579	1	JIM	Net 30

LINE	QTY	UNIT	PROD	DESCRIPTION	UNIT PRICE	EXT PRICE
1	1	EA	24127	CFE STRIKE TEAM SLIP-ON PACKAGE, END MOUNT 400 GALLON POLY TANK, 2" SQUARE TUBE ALUMINUM SUB FRAME, ALUMINUM DIAMOND PLATE PUMP AND TANK PLATFORM(S), 18HP/CF-120 HIGH PRESSURE PUMP, STAINLESS STEEL CONTROL PANEL SCHEDULE 40 SEAMLESS STAINLESS STEEL PLUMBING MANIFOLD(S), STRIKETEAMDROP-OUT STYLE VALVES (1) 2.0" TANK TO PUMP, (1) 1.5", OVERBOARD DISCHARGE, (1) 1.0" PUMP TO TANK, (1) 1.0", HOSE REEL SHUT-OFF, ELECTRIC PRIMER, HANNAY F SERIES FULLFLOW REEL, 100' LIGHTWEIGHT BOOSTER HOSE, 1.0" RANGER PLUS NOZZLE	22,780.00	22,780.00
2	1	EA	24068	LIVE HOSE TRAY W/ BUILT IN EQUIPMENT DRAWER SMOOTH ALUMINUM FINISH, TURTLE TILE, KEYED ALIKE (REUSE EXISTING BOX, PLUMBING ONLY)	790.00	790.00
3	1	EA	24083-2.5P	HYDRANT FILL, 2.5"	795.00	795.00
5	1	EA	25012	INTELLITANK WATER LEVEL GAUGE(REUSE EXISTING)	0.00	0.00
6	1	EA	24066P	SINGLE HOSE ROLLER AND GUIDES, CHROME (REUSE EXISTING)	0.00	0.00
7	1	EA	11685P	ALUMINUM REEL ON SLIP-ON (REUSE EXISTING)	0.00	0.00



**CASCADE FIRE  
EQUIPMENT COMPANY**

P.O. BOX 4248 • MEDFORD, OREGON 97501  
(800) 654-7049 • (541) 779-0394 • Fax (541) 779-8847  
[sales@cascadefire.com](mailto:sales@cascadefire.com) • [www.cascadefire.com](http://www.cascadefire.com)

**QUOTE**

ACCOUNT 0000908

SHIP TO SOUTH LAKE COUNTY F. P. D.  
PO BOX 1360  
MIDDLETOWN CA

DATE		QUOTE NO.		SALESPERSON	TAKEN BY	PAY TYPE	
10/16/20		102645		1	JIM	Net 30	
LINE	QTY	UNIT	PROD	DESCRIPTION		UNIT PRICE	EXT PRICE
1	1	EA	F175-OB	BUCKSTOP HD BUMPER, BRUSH GUARD, WINCH MOUNT, INSTALLED		2,550.00	2,550.00
2	1	EA	103254	WARN 12,000 LB WINCH AND REMOTE, INSTALLED		1,250.00	1,250.00
3	1	EA	STD-A-TOPBASKET	TANK TOP EQUIPMENT BASKET, INSTALLED		1,135.00	1,135.00
4	2	EA	SO BASKETS	SIDE COMPARTMENT TOP BASKETS, INSTALLED		690.00	1,380.00
5	1	EA	SUPER SINGLE	DBL SUPER SINGLE CONVERSION, INSTALLED 20 X 10 THREE PIECED FORGED ALUMINUM WHEELS, 335/80R20 CONTINENTAL TIRES, GEAR INTALLATION KIT WITH 6.17 RATIO GEARS, 2.5" LIFT WITH FOX SHOCKS, SWAY BAR, FENDERS, SPEEDOMETER KIT, AMP STEPS		19,997.00	19,997.00
6	1	EA	UF201	TROY PRODUCTS CENTER CONSOLE, INSTALLED WITH: SUNGLASS HOLDER BEVERAGE HOLDER MAGNETIC MIC'S 6" LEATHER ARM PAD WITH BRACKET USB/12V PLATE WITH		1,268.00	1,268.00



**CASCADE FIRE  
EQUIPMENT COMPANY**

P.O. BOX 4248 • MEDFORD, OREGON 97501  
 (800) 654-7049 • (541) 779-0394 • Fax (541) 779-8847  
[sales@cascadefire.com](mailto:sales@cascadefire.com) • [www.cascadefire.com](http://www.cascadefire.com)

				INSERTS PATHFINDER REMOTE SIREN PLATE		
				FEDERAL SIGNAL LIGHTING PACKAGE, INSTALLED INCLUDES: 53" ALLEGIANT SERIAL LED LIGHTBAR, HOOK MOUNT - RED/WHITE 24 LED MICRO PULSE LIGHTS - X4 GRILL LIGHTS R/W 24 LED MICRO PULSE LIGHTS - X2 FENDER LIGHTS R/W 24 LED MICRO PULSE LIGHTS - X6 SIDE LIGHTS R/W 24 LED MICRO PULSE LIGHTS - X2 REAR LIGHTS R/W 24" LATITUDE REAR FACING LIGHT - DIRECTIONAL AMBER COMMANDER WORK LIGHTS - X4 UNIVERSAL HEADLIGHT FLASHER UNIVERSAL TAILLIGHT FLASHER EXPANSION MODULE  PATHFINDER SIREN/LIGHT MODULE DYNAMAX SPEAKERS - X2		
7	1	EA	FED SIG		9,088.00	9,088.00

TOTAL FREIGHT	TOTAL TAX	TOTAL
0.00	2,658.43	39,326.43

VALID FOR 60 DAYS



**CASCADE FIRE  
EQUIPMENT COMPANY**

P.O. BOX 4248 • MEDFORD, OREGON 97501  
(800) 654-7049 • (541) 779-0394 • Fax (541) 779-8847  
[sales@cascadefire.com](mailto:sales@cascadefire.com) • [www.cascadefire.com](http://www.cascadefire.com)

8	1	EA	CFE100	CFE SPEC ALUMINUM FLATBED, 120" x 96" W/ SUCTION HOSE TUBES (X3), DUAL REAR STEPS, LED MARKER LIGHTS, CLASS III 2" HITCH RECIEVER	8,360.00	8,360.00
9	1	EA	L2	DRIVER SIDE BOX(66"x21.5"x43.5") - 3 DOOR DESIGN ALUMINUM FINISH, ADJUSTABLE SHELVES, LED LIGHTING, GAS SHOCKS, TURTLE TILE, KEYED ALIKE DROP DOWN DOORS TO HAVE WIDE CHANNEL (REUSE EXISTING)	0.00	0.00
10	1	EA	L1	DRIVER SIDE BOX(66"x21.5"x43.5") - 2 DOOR DESIGN ALUMINUM FINISH, ADJUSTABLE SHELVES, LED LIGHTING, GAS SHOCKS, TURTLE TILE, KEYED ALIKE DROP DOWN DOOR TO HAVE WIDE CHANNEL (REUSE EXISTING)	0.00	0.00
11	2	EA	U2	UNDER BODY BOX(36"x18"x18") - DROP DOWN STYLE ALUMINUM FINISH, KEYED ALIKE (REUSE EXISTING)	0.00	0.00
12	2	EA	ELSS-SLDC-PU	SCENESTAR 14,000 LUMEN LED	0.00	0.00
13	1	EA	C/F BOX	CROSS FRAME BOX(96"x43.5"x20") - PULL OUT DRAWER STYLE ALUMINUM FINISH, KEYED ALIKE (REUSE EXISTING)	0.00	0.00
14	1	EA	U/R BOX	UNDER REEL EQUIPMENT DRAWER ALUMINUM FINISH, TURTLE TILE, KEYED ALIKE (REUSE EXISTING)	0.00	0.00
15	2	EA	21229	BRACKET, CHOCK MEDIUM UNDERBODY (REUSE EXISTING)	0.00	0.00
16	2	EA	21216	CHOCK, MEDIUM DUTY, ALUMINUM (REUSE EXISTING)	0.00	0.00
17	1-	EA	81204	CREDIT, 1.5" CFE INLINE VALVE, DISCHARGE	(265.00)	(265.00)
18	1-	EA	11122CH	CAP, 1.5"NH,R/L CHROME		
19	1-	EA	81200	CFE VALVE, 1½"-NO FLANGE		
20	1-	EA	81200-22	FLANGE, 1½" NH (M)		
21	1-	EA	81200	CREDIT, CFE VALVE, 1½", HOSE TRAY PRECONNECT	(225.00)	(225.00)
22	2-	EA	81100	CREDIT, CFE VALVE, 1", TANK FILL, HOSE REEL	(186.00)	(372.00)
23	1-	EA	81300-23	CREDIT, CFE VALVE ,2 X 2.5" NH (F) SWIVEL, HYDRANT FILL	(300.00)	(300.00)



**CASCADE FIRE  
EQUIPMENT COMPANY**

P.O. BOX 4248 • MEDFORD, OREGON 97501  
 (800) 654-7049 • (541) 779-0394 • Fax (541) 779-8847  
[sales@cascadefire.com](mailto:sales@cascadefire.com) • [www.cascadefire.com](http://www.cascadefire.com)

24	1-	EA	81304	CREDIT, CFE VALVE 2" TANK TO PUMP SUCTION	(240.00)	(240.00)
25	1-	EA	11123CH	CAP,2"NPSH, R/L CHROME		
26	1-	EA	81300	CFE VALVE, 2", FLANGELESS		
27	1-	EA	81300-22	FLANGE, 2" NPSH (M)		
28	1-	EA	11663AD	CREDIT, HOSE REEL, STEEL 12V ELECTRIC	(1,350.00)	(1,350.00)
29	1-	EA	24063S-03	CREDIT, CFE CONTROL PANEL ASSY, 1 GAUGE	(1,100.00)	(1,100.00)
30	1-	EA	24191T	CREDIT, CF-120 TRUCK MOUNT PUMP, 18HP	(5,500.00)	(5,500.00)
34	1-	EA	10921NPSH	CREDIT, NOZZLE,RANGER 1"NPSH 10-30GPM	(60.00)	(60.00)
35	1-	EA	40700NPSH	CREDIT, SHUT-OFF HORSE SHOE HANDLE 1NPSH	(75.00)	(75.00)
36	1-	EA	31004	CREDIT, TANK, 150 GALLON POLY	(1,400.00)	(1,400.00)
37	1-	EA	11676X100NPSH	CREDIT, HOSE, BOOSTER LITE 1X100 NPSH	(340.00)	(340.00)
38	1	EA	INSTALLATION	DISASSEMBLE AND REINSTALL EXISTING ITEMS	3,300.00	3,300.00

TOTAL FREIGHT	TOTAL TAX	TOTAL
0.00	1,797.86	26,595.86

VALID FOR 60 DAYS

**BOARD OF DIRECTORS, SOUTH LAKE COUNTY FIRE PROTECTION DISTRICT**  
**COUNTY OF LAKE, STATE OF CALIFORNIA**

**RESOLUTION NO. 2020-21- 09**

**A RESOLUTION TRANSFERRING AND APPROPRIATING CONTINGENCIES,  
AND ESTABLISHING AND APPROPRIATING OVER-REALIZED / UNANTICIPATED  
REVENUES FROM INSURANCE AND SALES PROCEEDS FOR REPURPOSING OF  
2003 CHEVROLET AMBULANCE TO TYPE 6 ENGINE 6061 AND ITS REPAIRS**

1           **WHEREAS, GOVERNMENT CODE 29125**, provides that transfers and revisions from  
2 contingencies may be available for specific appropriation by a four-fifths vote of the Board at a  
3 noticed public hearing held as part of any regular or special meeting of which all members have had  
4 reasonable notice; and,

5           **WHEREAS, GOVERNMENT CODE 29130**, provides that over-realized unanticipated  
6 revenue may be available for specific appropriation by a four-fifths vote of the Board at a noticed  
7 public hearing held as part of any regular or special meeting of which all members have had  
8 reasonable notice; and,

9           **WHEREAS**, since 2015, South Lake County Fire Protections District's 293 square miles has  
10 been damaged, destroyed and threatened by over a dozen major wildland fires in which this type of  
11 vehicle would have been used on most, if not all those fires; and,

12           **WHEREAS**, while repurposed Engine 6061 was driven home, an engine fire causing  
13 damage to the firewall and some wiring harnesses made vehicle nonfunctional; and,

14           **WHEREAS**, the best option is to replace the damaged cab and chassis.

15           **NOW, THEREFORE, BE IT RESOLVED AND DIRECTED THAT**

16           the sum of \$\_\_\_\_\_, be transferred and appropriated

17                     From Fund no. 357, Account No. 9557-795.90-91

18                     To Fund no. 357, Account No. 9557-795.62-72

19           the sum of \$11,931 in over-realized / unanticipated revenue is hereby appropriated

20                     From Fund no. 357, Account No. 9557-492.79-93

21                     To Fund no. 357, Account No. 9557-795.62-72

22                     for return of overpayment as noticed by DHCS attached hereto.

23           **THIS RESOLUTION** was introduced and adopted by the Board of Directors of the South  
24 Lake County Fire Protection District on the 15<sup>th</sup> day of December, 2020 by the following vote:

AYES:

NOES:

ABSENT OR NOT VOTING:

SOUTH LAKE COUNTY  
FIRE PROTECTION DISTRICT

---

MADELYN MARTINELLI  
President, Board of Directors

ATTEST: \_\_\_\_\_  
Gloria Fong  
Clerk to the Board of Directors



**South Lake County Fire Protection District**  
— in cooperation with —  
**California Department of Forestry and Fire Protection**

---

P.O. Box 1360 Middletown, CA 95461 - (707) 987-3089

**DATE:** August 15, 2020  
**TO:** Board of Directors  
**FROM:** Gloria Fong  
Staff Services Analyst  
**SUBJECT:** Resolution No. 2020-21-03, A Resolution Adopting Budget for Fiscal Year 2020-2021

For the Board's consideration is subject resolution. Following the resolution is the transmittal to County of Lake Auditor-Controller's Office. Please note it is check "yes" to allow them to adjust general reserves, as noted in resolution. The reason is final tabulation reports have not been sent out by their office yet. The reports I have are missing 50% HOPTR, 5% Teeter, final quarter interest, and final Direct Charge postings. I have estimated this to best I can to prepare adopted budget.

The increases, decreases follow. My apologies for no specific order and intended to provide an explanation of increase, decrease. These will appear on the four detailed pages following the budget summary.

Expenses

- \$1,210 annually for Target Solutions Check It App for inventorying, accountability, and transparency. This app can inventory everything from PPE to equipment and apparatus, with notification capabilities when ABC 90-day inspections are required. It also can track narcotic inventory and its movement on from location to another, avoiding possibility of misplacing paper files. Cal Fire is currently looking into utilizing this app. This is a yearly commitment with possibility of the Cal Fire paying for it in the future. Agreement addendum attached.
- \$27,062 each for three patient auto load systems for M6211, M6311, and M6011. Employees are most critical resource. Workplace injuries have a fiscal impact. While none of our injuries have been a direct result of loading patients, it is the first step in providing workplace safety. Years ago, gurneys that go up and down were purchased. With this system, platform mounted to the ambulances, it accepts and locks the gurneys in place, then slides the patient into the ambulance. Quotes attached, one for two systems and a second for one system (being revised to include sales tax).
- \$235,949 for new ambulance, M6311. The ambulance was received first week of July and its expense is incorporated into this fiscal year's budget.
- \$17,645 for pavement, seal and strip at Middletown Station 60 to prevent additional wear and damage. Three bids were received, \$23,850 from Epidendio Construction, \$33,935 from American Asphalt and \$17,645 from S&K Paving Sealing & Striping Inc.



- \$4,676 for emergency, fire escape at Hidden Valley Lake Station 63 sleeping quarters. This will be a steel emergency, fire escape. Three bids were received, \$4,676 from Weidners Welding, \$10,185 from MP Industries, and \$9,110 from Morris Welding.
- \$585 each application (\$1,170 annually) for weed eradication at Middletown Station 60. Three bids were received, \$585 each application from Armed Force Pest Control, \$1,110 each application from RB Pest Control, \$1,350 each application from Predator Pest and Weed.
- \$27,975 for SCBA bottles approved at 03/17/2020 Board meeting. Summary provided for that meeting attached. Bottles weren't available until late May early June to ship. Purchase held off with funds to be budget for their purchase this fiscal year.
- \$4,000 for Hidden Valley Lake Station 63 property survey. Survey is in preparation for expansion and includes pins and survey set. Bids were received, with one no bid from Ruzicka Associates, \$6,500 from Conser Land Surveying, and \$4,000 from Albion Surveys Inc.
- \$4,189 for Cal Fire Training Bureau. Recommended is increased to match balance being carried over.
- \$5,500 for gas monitor, calibration system (2) 36-month lease. Staff summary attached.
- \$20,000 was donated by Lake County Wine Alliance and is yet to be allocated for an expense.

#### Revenue

- \$937,660 increase to fund balance. Estimate is higher than that provided in recommended back in May. Reasons are \$200,000 budgeted for ambulance is carried over to this fiscal year. Increase of about \$200,000 in IGT funds (\$180k was budgeted and \$409k was receipted). The balance of about \$125k is due to receipt of supplemental property tax, disaster property tax loss relief fund, and difference between Cal Fire actual and budgeted costs. In addition, there is a return of about \$59k from Cal Fire due actual costs being less than estimated invoice for fourth quarter.
- From the aforementioned, the \$409k from IGT funds and \$25k from Redbud Health Care District is being placed into medical equipment replacement reserves along with \$544k from Assistance by Hire (ABH) funds.
- Redbud Health Care District assisted with fund the purchase of ambulance a few years ago, M6211 and the intent with this grant funding is to replenish the medical equipment replacement reserves.
- ABH is invoiced for personnel and equipment aiding in State Responsibility fires, and mutual aid (Cal OES) requests for responses to State fires. The \$544k is net from last four fiscal years.

	<u>Total</u>	<u>Equipment</u>	<u>Personnel</u>	<u>Expenses</u>	
<u>FY 2016-17</u>	211,391.31	143,546.20	67,845.11	9,443.52	
<u>FY 2017-18</u>	427,589.96	181,345.15	246,244.81	14,096.68	
<u>FY 2018-19</u>	318,956.30	214,767.40	104,188.90	1,189.30	
<u>FY 2019-20</u>	77,656.49	43,556.41	34,100.08	14,194.69	
	<u>1,035,594.06</u>	<u>583,215.16</u>	<u>452,378.90</u>	<u>38,924.19</u>	<u>544,290.97</u>

Property tax is increased \$10,152, an estimate based on the 55% and 40% Teeter District has already received.

Interest is increased \$25,000. This is an estimate of the final quarter interest based on higher cash balances held on deposit with the County of Lake.

Other governmental agencies is reduced by \$78,000.

Other services – fire protection is increased by \$45,000. This is based on the reports provided by the County of Lake Auditor-Controller’s direct charges division of their office.

\$321,201 in fire mitigation fee funds are transferred into operating. These funds must be expended within five years of receipt. Otherwise they are to be returned. The year before \$980 was deposited in the operating fund rather than fire mitigation fee, is carried over, applied towards the District’s share (25%) for generator project. The year before \$26,000 had been transferred in and is carried over. Funds of is transferred in for \$31,120 balance expended for generators last fiscal year, \$235,950 for ambulance and \$54,131 for two auto load systems.

Please also refer to attached that is already included when Recommended was adopted in May.

Attachments

MUTUAL AID / ABH - EQUIPMENT REIMB  
 FY 2016-17

<u>Eqt.</u>	<u>Inc. Name</u>	<u>Inc. #</u>	<u>Req. #</u>	<u>Start Date</u>	<u>Doc #</u>	<u>Amt Rec'd</u>	<u>Ck Rec'd</u>	<u>Pers Amt</u>	<u>Eqt Amt</u>
Vibe	Reservoir	CALNU005586	O-25	6/27	1UI5L184	188.00	9/7/2016		188.00
Vibe	Reservoir	CALNU005586	O-25	7/1	1UI6L007	141.00	9/2/2016		141.00
Vibe	Foothill	CALNU006532	O-22	7/19	1UI6L008	282.00	9/2/2016		282.00
WT6011	Morgan	CALNU006617	E-9	7/22	1U6F2304	930.72	1/11/2017	290.72	640.00
OES359	Soberanes	CABEU03422	E-171	7/24	20162633	23,116.08	5/16/2017	23116.10	
E6031	LNU July Move Up	CALNU005776	E-31	7/25	1U6F2301	12,400.00	1/11/2017		12400.00
WT6011	North Branch	CALNU006965	E-3	7/29	1U6F2305	930.72	1/11/2017	290.72	640.00
WT6411	North Branch	CALNU006965	E-12	7/29	1U6F2306	1,123.52	1/11/2017	483.52	640.00
E6031	LNU Aug. Move Up	CALNU007072	E-1	8/1	1U6F2302	2,760.00	1/11/2017		2760.00
E6031	Cold	CALNU007135	E-75	8/2	1U6F1136	7,320.00	9/20/2016		7320.00
E6031	LNU Aug. Move Up	CALNU007072	E-31	8/6	1U6F2303	20,720.00	1/11/2017		20720.00
WT6011	Kugelman	CALNU007396	E-8	8/9	1U6F2307	872.55	1/11/2017	272.55	600.00
WT6411	Canyon	CALNU007397	E-12	8/9	1U6F2308	1,123.52	1/11/2017	483.52	640.00
WT6411	Clayton	CALNU007582	E-131	8/13	1U6F1712	13,369.29	9/22/2016	3689.29	9680.00
WT6011	Clayton	CALNU007582	E-4	8/13	1U6F1727	15,800.07	9/22/2016	4360.07	11440.00
E6032	Clayton	CALNU007582	E-50	8/13	1U6F1714	20,553.08	9/22/2016	10873.08	9680.00
WTRTANK	Clayton	CALNU007582	S-41	8/13	1U6F1912	2,700.00	10/19/2016		2700.00
U6021	Clayton	CALNU007582	E-307	8/19	1UI6D511	768.00	10/19/2016		768.00
MOTL	Clayton	CALNU007582	O-348	8/21	1UI6F148	363.40	11/22/2016	363.40	
WT6411	Twenty	CALNU007887	E-2	8/22	1U6F2309	930.72	1/11/2017	290.72	640.00
E6031	LNU Aug. Move Up	CALNU007072	E-79	8/23	1U6F2311	17,280.00	1/11/2017		17280.00
WT6411	Mockingbird	CALNU008169	E-7	8/30	1U6F2310	1,512.42	1/11/2017	472.42	1040.00
E6031	LNU Sep. Move Up	CALNU008217	E-3	9/1	1U6F2313	17,840.00	1/11/2017		17840.00
E6031	LNU Sep. Move Up	CALNU008217	E-12	9/11	1U6F2314	10,560.00	1/11/2017		10560.00
E6032	LNU Sep Move Up	CALNU008217	E-16	9/11	1U6F2312	6,087.98	1/11/2017	3127.98	2960.00
U6021	Willard	CALMU004695	O-176	9/12	2UI6J565	672.00	10/17/2016		672.00
WT6411	Sawmill	CALNU009129	E-15	9/25	1U6F2317	1,221.57	3/9/2017	381.57	840.00
WT6011	Sawmill	CALNU009129	E-14	9/25	1U6F2316	5,351.64	3/9/2017	1671.64	3680.00
E6031	Sawmill	CALNU009129	E-17	9/25	1U6F2315	5,429.82	1/11/2017	2789.82	2640.00
U6421	Sawmill	CALNU009129	E-103	9/26	1U6F2318	192.00	1/11/2017		192.00
Lodging	Kiko	CACNR000535			1U6F2319	2,120.00	1/19/2017		2120.00
U6021	Loma	CASCU006912	O-123	9/27	1U6S2539	576.00	11/2/2016		576.00
OES359	Little Valley	NVNWS030641	E-171	10/14	201630641	14,887.99	12/5/2018	14887.99	
Total						<b>211,391.29</b>		<b>67,845.11</b>	<b>143,546.20</b>

MUTUAL AID / ABH - Personnel Equipment Reimbursement Summary  
 FY 2017-18 YTD 12/31/2017

<u>Eqt.</u>	<u>Inc. Name</u>	<u>Inc. #</u>	<u>Req. #</u>	<u>Start Date</u>	<u>Doc #</u>	<u>Amt Rec'd</u>	<u>Date Rec'd</u>	<u>Pers Amt</u>	<u>Eqt Amt</u>
Vibe	Winter	CALNU006262	O-157	7/7	1U7F1363	1,808.00	5/3/2018	1,620.00	188.00
WT6411	Smith	CALNU006018	E-11	7/1	1U7F1334	1,191.37	9/14/2017	511.37	680.00
E6031	LNU July Move Up	CALNU006021	E-32	7/8	1U7FXXXX	13,369.75	5/3/2018	3,209.75	10,160.00
E6032	LNU July Move Up	CALNU006021	E-44	7/12	1U7F1362	2,080.00	5/3/2018		2,080.00
OES359	Alamo	CASLU007624	E-232	7/9	U-20177437	4,128.76	11/2/2017	4,128.76	
OES359	SLU July Move Up	CASLU007319	E-22.5	7/10	U-2078625	5,585.98	3/22/2019	5,585.98	
E6031	Murphy	CALNU006709	E-14	7/17	<12 hrs				
WT6411	Murphy	CALNU006709	E-14	7/17	1U7F1354	2,592.97	5/3/2018	1,112.97	1,480.00
WT6011	Foothill	CALNU007092	E-14	7/27	not invoiced				
E6031	Foothill	CALNU007092		7/27	<12 hrs				
OES359	Minerva 5	CAPNF001043	E-023	7/30	F-20173813	30,849.12	12/20/2017	30,849.10	
E6031	Bottle	CALNU007582		8/8	<12 hrs				
WT6411	Bottle	CALNU007582	E-16	8/8	1U7FXXXX	2,975.18	5/3/2018	895.18	2,080.00
OES359	Chetco Bar Fire	CAOES002278	E-1	8/20	O-20172028	15,379.78	7/31/2018	15,379.78	
WT6411	Water	CALNU008279	E-11	8/27	1U7FXXXX	829.62	5/3/2018	249.62	580.00
E6031	August Cover	CALNU007281	E-39	8/29	1U7FXXXX	25,143.57	5/3/2018	6,343.57	18,800.00
E6032	August Cover	CALNU007281	E-58	8/30	1U7FXXXX	23,040.00	5/3/2018		23,040.00
U6021	Ponderosa	CABTU013737	O-162	8/30	2U7H3595	844.80	10/5/2017		844.80
OES359	Helena	CASHF001770	E-24.3	8/31	F-20174044	32,935.14	1/30/2018	32,935.12	
WT6011	Mule	CALNU008729	E-18	9/5	1U7FXXXX	915.44	5/3/2018	275.44	640.00
WT6011	Hofacker	CALNU009527	E-1	9/25	1U7FXXXX	743.80	5/3/2018	223.80	520.00
E6221	Sulphur	CALNU010055	E-34	10/9	1U7F6107	13,056.00	11/21/2017		13,056.00
E6421	Sulphur	CALNU010055	E-33	10/9	1U7F6107	21,200.76	11/21/2017	7,736.76	13,464.00
E6011	LNU Oct Move Up & Cvr	CALNU009785	E-45	10/9	1U7F1472	20,474.55	5/3/2018		20,474.55
U6021	LNU Central Complex	CALNU010104	O-518	10/11	1U7F3232	1,152.00	12/19/2017		1,152.00
E6032	LNU Oct Move Up & Cvr	CALNU009785	E-46	10/9	1U7F1473	17,646.00	5/3/2018		17,646.00
WT6011	Ridge	CALNU009953	E-40	10/6	1U7F1475	2,939.91	5/3/2018	1,273.91	1,666.00
WT6011	LNU Staffing	CALNU009947	O-4	10/8	1U7F1474	1,794.24	5/3/2018	842.10	952.00
WT6011	Patrick	CALNU010046	E-7	10/8	not invoiced				
WT6011	LNU Central Complex	CALNU010104	E-296	10/13	1U7F4071	21,074.90	12/19/2017	10,602.90	10,472.00
U6421	LNU Central Complex	CALNU010104	C-54.1	10/16	1U7F4070	1,248.00	12/19/2017		1,248.00
P1426	Partrick	CALNU010051	O-4	10/9	not invoiced				
P1426	LNU Central Complex	CALNU010104	O-815	10/17	not invoiced				
Vibe	Tubbs	CALNU010045	O-227	10/9	1U7F4156	1,786.00	12/19/2017		1,786.00
U6221	Tubbs	CALNU010045	E-411	10/25	1U7F4069	2,146.95	12/19/2017	1,858.95	288.00
E6031	Tubbs	CALNU010045	E-251	10/8	U-20172650	84,873.82	4/12/2018	64,603.02	20,270.80
U6321	Creek	CALAC362189	O-38	12/6	3U7B1317	430.00	2/21/2018		430.00
E6031	Creek	CALAC362189	E-140	12/6	U-20173327	15,484.80	4/12/2018	11,819.61	3,665.20
E6031	Thomas	CAVNC103156	E-10015	12/9	U-20173564	57,211.57	5/8/2018	43,635.36	13,576.20
U6421	Thomas-travel	CAVNC103156	E-10015	12/16	U-20173564	657.21	5/8/2018	551.60	105.60
<b>Total</b>						<b>427,589.99</b>		246,244.65	181,345.15

MUTUAL AID / ABH - Personnel Equipment Reimbursement Summary  
 FY 2018-19 YTD 05/31/2019

<u>Eqt.</u>	<u>Inc. Name</u>	<u>Inc. #</u>	<u>Req. #</u>	<u>Start Date</u>	<u>Doc #</u>	<u>Amt Rec'd</u>	<u>Date Rec'd</u>	<u>Amt Pending</u>	<u>Pers Amt</u>	<u>Eqt Amt</u>
U6011	Pawnee	CALNU009002	E-350	6/26	1U7F6616	1,056.00	8/27/2018			480.00
U6221	Pawnee	CALNU009002	O-15	6/25	1U7F6616 *					576.00
U6011	Pawnee	CALNU009002	E-350	7/1	1U8F1723	1,326.90	8/28/2018			384.00
U6221	Pawnee	CALNU009002	O-15	7/1	1U8F1723 *					864.00
E6011	Pawnee	CALNU009002	E-488	7/6	1U8F1723 *					78.90
E6321	Pawnee	CALNU009002	E-299	6/23	1U7F6189	27,578.20	8/27/2018			9,367.00
WT6011	Pawnee	CALNU009002	E-288	6/23	1U7F6189 *			8,691.20		9,520.00
E6011	County	CALNU009502	E-575	7/6	1U8F1418	12,229.50	10/9/2018			12,229.50
E6031	June Move Up	CALNU007392	E-33	6/24	1U7F6685	10,200.00	8/27/2018			10,200.00
Vibe	Pawnee	CALNU009002	O-358	6/26	1U7F6616	235.00	9/12/2018			235.00
Vibe	County	CALNU009502	O-196	7/1	1U7F6616	1,410.00	10/9/2018			1,410.00
WT6011	Spring	CALNU010121	E-31	7/9	1UI8FXXX	1,634.04	2/19/2019		767.04	867.00
WT6011	Carder	CALNU010957	E-10	7/21	1UI8F777	2,691.36	2/19/2019		1,263.36	1,428.00
WT6011	Steele	CALNU011447	E-24	7/28	1UI8F776	2,306.88	2/19/2019		1,082.88	1,224.00
POV	County	CALNU009002	O-623	7/8	not inv'd	0.00				
U6021	Pawnee	CALNU009002	E-80	6/24	U-20180409	6,209.46	1/11/2019		5,681.46	528.00
OES359	Carr	CASHU007808	E-824	8/1	U-20185201	48,001.91	3/11/2019		48,001.91	
WT6011	Cache	CALNU013335	E-27	8/26	1UI8F763	2,306.88	2/19/2019		1,082.88	1,224.00
WT6011	Grade	CALNU013577	E-14	8/30	1UI8F764	870.66	2/19/2019		292.66	578.00
E6031	June Move Up	CALNU007392	E-33	6/30	1UI9F209	35,700.00	11/5/2019			35,700.00
E6421	August Move Up	CALNU011689	E-1	8/16	1UI8F802	8,160.00	11/5/2019			8,160.00
E6421	Mendocino Complex	CAMEU008674	E-599.5	8/4	1UI8FXXX	19,584.00	2/19/2019			19,584.00
E6031	August Move Up	CALNU011689	E-36	8/15	1UI8F762	4,624.00	2/19/2019			4,624.00
E6031	Hirz	CASHF001223	E-200005	8/18	1UI8FXXX	28,628.00	3/13/2019			28,628.00
E6031	September Move Up	CALNU013692	E-17	9/4	1UI8F761					1,360.00
E6031	September Move Up	CALNU013692	E-46	9/13	1UI8F761	3,264.00	2/19/2019			1,904.00
E6032	Snell	CALNU014193	E-18	9/8	1U8F3818	3,154.75	12/20/2018		1,760.75	1,394.00
WT6011	Snell	CALNU014193	E-21	9/8	1U8F3817	15,795.72	12/20/2018		7,414.72	8,381.00
Vibe	Snell	CALNU014193	O-80	9/9	not inv'd	0.00				
WT6011	Ridge	CALNU013781	E-14	9/2	1UI8F766	3,043.80	2/19/2019		1,428.80	1,615.00
WT6011	Kelsey	CALNU013848	E-15	9/3	1UI8F765	1,281.60	2/19/2019		601.60	680.00
E6032	LNU July Cover	CALNU009561	E-101	7/19	1UI8F760	51,544.00	2/19/2019			51,544.00
OES359	Camp	CABTXXXXXX	E-56	11/8	U20186161	26,119.64	5/30/2019		26,119.64	
<b>Total</b>						<b>318,956.30</b>		<b>0.00</b>	104,188.90	214,767.40

MUTUAL AID / ABH - Personnel Equipment Reimbursement Summary  
 FY 2019-20 YTD 05/31/2019

<u>Eqt.</u>	<u>Inc. Name</u>	<u>Inc. #</u>	<u>Req. #</u>	<u>Start Date</u>	<u>Doc #</u>	<u>Amt Rec'd</u>	<u>Date Rec'd</u>	<u>Amt Pending</u>	<u>Pers Amt</u>	<u>Eq Amt</u>
E6031	Golf	CALNU013990	E-38	8/8	1UI9F205	6,597.31	11/5/2019		3,230.00	3,367.31
WT6411	Glass	CALNU015917	E-25	9/4	1UI9F1607	4,247.44	4/22/2020		2,377.44	1,870.00
WT6011	Oak	CALNU016101	E-37	9/7	1UI9F1608			7,610.59	2,969.59	4,641.00
U6321	Henthorne			9/6	not inv'd					
WT6011	Grove	CALNU018945	E-12	10/17	1UI9F1610	1,434.02	4/22/2020		482.02	952.00
WT6011	Kincade	CALNU019376	E-274	10/23	1UI9F4382	3,074.16	1/14/2020		512.16	1,122.00
U6421	Kincade	CALNU019376	O-663	10/10	1UI9F4382					1,440.00
E6011	LNU October Move Up	CALNU017726	E-274	10/25	1UI9F16011	25,011.30	4/17/2020			25,011.30
WT6011	Eagle	F19CALNU020533	E-21	11/4	1UI9F1609	1,690.10	4/22/2020		568.10	1,122.00
WT6411	Eagle	F19CALNU020533	E-22	11/4	1UI9F1609	1,638.88	4/22/2020		550.88	1,088.00
OES359	Kincade	CALNU019376	E-201	10/25	U20186161	22,204.29	6/1/2020		22,204.29	
WT6411	Spanish	CALNU007483	E-13	5/22				1,703.73	329.48	1,374.25
WT6411	Oat	CALNU007994	E-11	5/28				740.75	143.25	597.50
WT6411	Whisner	CALNU007994	E-11	5/30				962.98	186.23	776.75
WT6411	Mule	CALNU009336	E-13	6/20				1245.86	409.36	836.50
WT6411	Boyles	CALNU008590	E-13	6/20				1185.20	229.20	956.00
<b>Total</b>		<b>Total</b>				<b>65,897.50</b>		<b>13,449.11</b>	34,192.00	45,154.61



**South Lake County Fire Protection District**  
— in cooperation with —  
**California Department of Forestry and Fire Protection**

---

P.O. Box 1360 Middletown, CA 95461 - (707) 987-3089

**DATE:** December 12, 2020  
**TO:** Board of Directors  
**FROM:** Gloria Fong  
Staff Services Analyst  
**SUBJECT:** Resolution No. 2020-21-10, A Resolution Transferring and Appropriating Contingencies for Repeater to Improve Communications in Southern End of Lake County

Subject resolution is provided for Board's consideration and approval, with motion to include the acceptance of Donan's \$14,280 radio repeater bid. The resolution appropriates the \$12,000 Lake County Wine Alliance funds received last fiscal year.

Together with the \$5,000 Rockridge Foundation funds, the Repeater purchase and installation, location to be determined, will benefit all by improving communications in the southern end of Lake County.

The Board is asked to include in its motion the acceptance of the bid since the amount on the resolution is based on the Donan amount of \$14,280, as the compatible and complete bid.

- Attachments:
- 1) subject resolution
  - 2) Lake County Wine Alliance receipted funds
  - 3) Rockridge funds acknowledgement letter
  - 4) Repeater bids

**BOARD OF DIRECTORS, SOUTH LAKE COUNTY FIRE PROTECTION DISTRICT**  
**COUNTY OF LAKE, STATE OF CALIFORNIA**

**RESOLUTION NO. 2020-21- 10**

**A RESOLUTION TRANSFERRING AND APPROPRIATING CONTINGENCIES FOR REPEATER TO IMPROVE COMMUNICATIONS IN SOUTHERN END OF LAKE COUNTY**

1           **WHEREAS, GOVERNMENT CODE 29125**, provides that transfers and revisions from  
2 contingencies may be available for specific appropriation by a four-fifths vote of the Board at a  
3 noticed public hearing held as part of any regular or special meeting of which all members have had  
4 reasonable notice; and,

5           **WHEREAS**, together with the \$5,000 Rockridge Foundation funds, the purchase of  
6 Repeater for installation in the southern end of Lake County will improve communications.

7           **NOW, THEREFORE, BE IT RESOLVED AND DIRECTED THAT**

8           the sum of \$12,000 be transferred and appropriated

9                       From Fund no. 357, Account No. 9557-795.90-91

10                      To Fund no. 357, Account No. 9557-795.62-74

11           **THIS RESOLUTION** was introduced and adopted by the Board of Directors of the South  
12 Lake County Fire Protection District at a Regular Meeting on the 15<sup>th</sup> day of December, 2020  
13 by the following vote:

AYES:

NOES:

ABSENT OR NOT VOTING:

SOUTH LAKE COUNTY  
FIRE PROTECTION DISTRICT

\_\_\_\_\_  
MADELYN MARTINELLI  
President, Board of Directors

ATTEST: \_\_\_\_\_  
Gloria Fong  
Clerk to the Board of Directors



**Fw: Need your official department name**

Wink, Mike

Sat 12/14/2019 2:37 PM

Good afternoon SLCFPD BODs. This last Tuesday we received a \$12,000.00 donation from the Lake County Wine Alliance (<http://www.winealliance.org/>) to support our Emergency Response Mission. This will be a pass through expenditure that will continue to give the perception that we are spending more than we are receiving in revenue. Sincerely, Mike

Lake County Wine Alliance | Home

The Lake County Wine Alliance and the Lake County Rising Fire Relief fund have distributed \$137,461 over the past year. Thanks to everyone who helped make this year's event at Chacewater such a success.

[www.winealliance.org](http://www.winealliance.org)

---

**From:** Wink, Mike@CALFIRE

**Sent:** Saturday, December 7, 2019 2:55 PM

**Subject:** Re: Need your official department name

Good afternoon Judy. Thank you so much for the notification. I just want to confirm the location will be the:

Buckingham Clubhouse  
2855 Eastlake Drive  
Kelseyville Ca. 95451

Our recipient will be Battalion Chief Matt Macdonald, representing the

South Lake County Fire Protection District  
P.O.Box 1360  
21095 Hwy 175  
Middletown, Ca. 95461

Sincerely, Mike

**Mike Wink**

**Battalion Chief  
Middletown Battalion**

***CAL FIRE - South Lake County Fire Protection District***

**Sonoma - Lake - Napa Unit  
21095 Hwy 175 - P.O.Box 1360  
Middletown, Ca. 95461  
Office: 707.987-3089 ext 3  
Cell: 707.889.4225  
Fax: 707.987.9478**

12/16/2019

---

**From:** Judy Luchsinger

**Sent:** Saturday, December 7, 2019 1:23:30 PM

**To:** Bertelli, Greg

**Cc:** Robert Roumiguere

**Subject:** Need your official department name

**Warning:** this message is from an external user and should be treated with caution.

Hi Greg,

This is Judy from the Lake County Wine Alliance and fire fund. We need to have the name that you want the check made out to. The official name of your fire department or district. Remember that we're having the giveaway event December 10th at the Buckingham clubhouse at 5:30 pm.

See you there.

Judy

**LAKE COUNTY RISING FIRE RELIEF FUND  
LAKE COUNTY WINE ALLIANCE**

PO BOX 530  
KELSEVILLE, CA 95451

UNIPOLIA BANK  
1-866-4UNIPOLIA  
(1-866-486-7782)

0164  
96-505/1232  
1/22  
CHECK NUMBER

12/10/2019

PAY TO THE ORDER OF South Lake County Fire District

\$ \*\*12,000.00

DOLLARS

Twelve thousand and 00/100\*\*\*\*\*

South Lake County Fire Department  
21095 State Highway 175  
Middletown, CA 95461  
United States

MEMO

Thank you for your service 2019 Wine Auction

*[Handwritten Signature]*  
AUTHORIZED SIGNATURE

⑈000164⑈ ⑆123205054⑆ 4885251039⑈

LAKE COUNTY RISING FIRE RELIEF FUND

12/10/2019 South Lake County Fire District  
2019 Wine Auction

12,000.00

0164

Fire Fund

Thank you for your service 2019 Wine Auction

12,000.00

Security Features Included

Details on Back



**South Lake County Fire Protection District**  
— in cooperation with —  
**California Department of Forestry and Fire Protection**

---

P.O. Box 1360 Middletown, CA 95461 - (707) 987-3089

April 2, 2020

Rockridge Foundation  
1070 Bollinger Canyon Rd.  
Moraga, CA 94556

Dear Mr. Norman B. Livermore III for the Rockridge Foundation,

On behalf of the South Lake County Volunteer Firefighters Association, we would like to thank the Rockridge Foundation for the more than generous donation. To say that we were overwhelmed by this donation would be an extreme understatement.

The SLCVFFA is a group of community members who work together to assist with providing fire protection and community service to South Lake County. This donation will assist us with a new radio repeater to improve hand-held radio coverage and communication in the Middletown area specifically.

Saying "Thank You" seems so small when acknowledging your donation, but it is all we have. From all of the members of the SLCVFFA, a very sincere, and heartfelt, THANK YOU!

Sincerely,

Mike Wink  
South Lake County Fire  
Battalion Chief

Todd Fenk  
Volunteer Firefighters Assn.  
President

THE ROCKRIDGE FOUNDATION  
1070 BOLLINGER CANYON ROAD  
MORAGA, CALIFORNIA 94556

December 23, 2019

Mr. Mike Wink  
South Lake County Fire – Volunteer Firefighters  
P. O. Box 1360  
Middletown, CA 95461



Dear Mr. Wink:

I am writing you on behalf of the Rockridge Foundation to make a donation to your Volunteer Firefighters organization. We are happy to join the many others who have spoken words of high praise regarding the services you provided to the residents and landowners of Middletown during the Valley Fire of 2015 and the Tubbs Fire of 2017 and the more recent Kincade Fire of 2019. To this end, please find enclosed a check for \$5,000.

The Rockridge Foundation was established by John S. Livermore and his four brothers to allow the Livermore Family to make charitable contributions to causes which match the values, ethics, and interests of our forbears. We know that you will put this money to good use, benefiting the residents of Middletown and environs.

Sincerely,

Norman B. Livermore III  
for the Rockridge Foundation

ROCKRIDGE FOUNDATION 100 COLUMBUS AVE. SAN FRANCISCO, CA 94133-5102	1070 Bollinger Canyon Rd Moraga, CA 94556	Morgan Stanley	1376
		DATE 12-23-19	25-80/440
PAY TO THE ORDER OF	South Lake County Fire - Volunteer Firefighters	\$ 5000.00	
	Five thousand 00/100		DOLLARS
Expense Analyzer			
FOR	Director 2019		
⑈001376⑈ ⑈044000804⑈8902014081601⑈			

# PURCHASE REQUEST

Date: NOV 2020 Amount Requested\*: \$17,000.00  
 Requestor's Signature: [Signature] Printed Name: MIKE WINK

*\*Requests for \$500 to \$4,999 require three verbal price quotes. Requests for \$5,000 to \$10,000 require three written price quotes. All price quotes shall include the vendor's name, phone no. and address as well as the detailed item and quantity being quoted.*

**REQUESTED FOR:**     Station 60     Station 62     Station 63     Station 64     Amador

**PURPOSE OF REQUEST:**

- |  |  |
|--|--|
| <input type="checkbox"/> Station Maintenance                     | <input type="checkbox"/> Equipment Maintenance |
| <input type="checkbox"/> Office Supplies                         | <input type="checkbox"/> Equipment Replacement |
| <input type="checkbox"/> Fire Prevention                         | <input type="checkbox"/> New Equipment         |
| <input type="checkbox"/> Training                                | <input type="checkbox"/> EMS Supplies          |
| <input checked="" type="checkbox"/> Emergency Operations         | <input type="checkbox"/> EMS Equipment         |
| <input type="checkbox"/> Vehicle No. _____                       | <input type="checkbox"/> To keep in Stock      |
| <input type="checkbox"/> Vehicle Maintenance: Veh. No. _____     | <input type="checkbox"/> Small Tools           |
| <input type="checkbox"/> Vehicle Repairs – Major: Veh. No. _____ | <input type="checkbox"/> Computers             |
| <input type="checkbox"/> Other: _____                            |  |

**Justification:** RADIO REPEATER TO IMPROVE HAND HELD RADIO USE IN MIDDLETOWN AREA ON LAKE RSD FREQ.  
~~\$\$\$~~ \$17,000.00 IN PART THROUGH FUNDING BEING USED.

**Recommendation:**

Qty	Vendor	Description	Estimated Cost
<u>1LOT</u>	<u>CODAN</u>	<u>RADIO REPEATER</u>	<u>\$14,280.00</u>
<u>1LOT</u>	<u>SANDY</u>	<u>NOT COMPATIBLE / INCOMPLETE</u>	<u>Ø</u>
<u>1LOT</u>	<u>VISION</u>	<u>NOT COMPATIBLE / INCOMPLETE</u>	<u>Ø</u>

**To be completed by Approving Official:**

- Denied      Reason: \_\_\_\_\_
- Approved    Amount: \$ \_\_\_\_\_  
 (If different from amount requested)

Signature: \_\_\_\_\_ Date: \_\_\_\_\_

**For Office Use Only:**

Purchase Order No.: \_\_\_\_\_  Order received/verified (i.e. dated & signed packing slip)  
 (w/o verification, invoice cannot be paid)

Type of Expenditure: \_\_\_\_\_ Line Item No.: \_\_\_\_\_

1) Completed request to be submitted to Approving Official for approval/denial;  
 2) Approved/denied copy will be returned to requestor; if approved, requestor makes purchase w/billing to be sent to South Lake County Fire Protection District's Office at 21095 State Hwy 175, P.O. Box 1360, Middletown, CA 95461. When purchased items are received, verification of receipt (i.e. packing slip marked "all items received", signed & dated) must be forwarded to the District Office.

Daniels MT-4E Radio Price for South Lake County Fire - OPP-21054

Mike@CALFIRE <Mike.Wink@fire.ca.gov>

21/2020 11:16 AM

Judd, Alan@CalOES <Alan.Judd@CalOES.ca.gov>

Cc: York, Brian@CALFIRE <Brian.York@fire.ca.gov>

1 attachments (11 KB)

Quote 20038979 South Lake Fire.pdf;

Alan, this one comes with the Duplexer. Is this the most complete quote? It is \$5,000.00+ more than other quotes.  
Mike

---

**From:** Alan McIntosh <Alan.McIntosh@CodanComms.com>

**Sent:** Wednesday, May 20, 2020 1:50 PM

**To:** Wink, Mike@CALFIRE <Mike.Wink@fire.ca.gov>

**Cc:** Rick Felt <Rick.Felt@CodanComms.com>; York, Brian@CALFIRE <Brian.York@fire.ca.gov>

**Subject:** Daniels MT-4E Radio Price for South Lake County Fire - OPP-21054

**Warning:** this message is from an external user and should be treated with caution.

Hi Mike,

The requested quote is attached for your review.

Thanks for your business and please don't hesitate to reach out with any questions.

Regards,

**Alan McIntosh**

Technical Sales Representative

**P:** +1 250-414-6297

**TF:** +1 800-664-4066 ext 297

**M:** +1 250-889-7901

**E:** [alan.mcintosh@codancomms.com](mailto:alan.mcintosh@codancomms.com)

<https://codancomms.com/lmr>

Daniels Electronics Ltd doing business as Codan Communications.

**From:** Wink, Mike@CALFIRE <Mike.Wink@fire.ca.gov>

**Sent:** Saturday, May 16, 2020 11:42 PM

**To:** Alan McIntosh <Alan.McIntosh@CodanComms.com>

**Cc:** Rick Felt <Rick.Felt@CodanComms.com>; York, Brian@CALFIRE <Brian.York@fire.ca.gov>

**Subject:** Re: Daniels MT-4E Radio Price for South Lake County Fire

**[EXTERNAL] This email was sent from outside of the Codan Group. Use caution when opening attachments or links from unknown senders.**

Tone 7 will be used by the First Responder on a hand held or mobile radio with OST. The first responder will choose OST 7 to use this new repeater. Or they can choose a different OST to pick a different repeater location. This repeater will only need to listen for Freq and OST 7 and ignore all others. Does that help? Mike

DUNS # 201185543  
Daniels Electronics Ltd. dba Codan Radio Communications  
43 Erie Street  
Victoria, B.C.  
V8V 1P8 Canada

# QUOTE # 20038979

Toll Free: 1-800-664-4066  
Phone: 1-250-382-8268  
Email: [lmrsales@codanradio.com](mailto:lmrsales@codanradio.com)

## QUOTE

## CUSTOMER

**Quote #:** 20038979  
**Date:** 20 May 2020  
**From:** Richard Earl  
**Customer:** Temporary US  
**Export Controlled:** Yes  
  
**Opportunity #:** 21054  
**Quote Subject:** Repeater for South Lake County Fire

**Contact:** Mike Wink  
**Address:** South Lake County Fire Protection District  
21095 Hwy 175  
Middletown CA  
95461

Line	Material	Material Description	Qty	Unit Price	Discount	Extended Price	Curr
000010	CCV-PACKAGES	30W P25 VHF Repeater	1.00	\$17,850.00	(\$3,570.00)	\$14,280.00	USD
<b>QUOTE TOTAL:</b>						\$14,280.00	USD



DUNS # 201185543  
 Daniels Electronics Ltd. dba Codan Radio Communications  
 43 Erie Street  
 Victoria, B.C.  
 V8V 1P8 Canada

# QUOTE # 20038979

Toll Free: 1-800-664-4066  
 Phone: 1-250-382-8268  
 Email: lmsales@codanradlo.com

## QUOTE

**Quote #:** 20038979  
**Date:** 20 May 2020  
**From:** Richard Earl  
**Customer:** Temporary US  
**Export Controlled:** Yes

## CUSTOMER

**Contact:** Mike Wink  
**Address:** South Lake County Fire Protection District  
 21095 Hwy 175  
 Middletown CA  
 95461

**Opportunity #:** 21054  
**Quote Subject:** Repeater for South Lake County Fire

CONTRACT TYPE	CONTRACT #	CONTRACT NAME
L1 Price List	COMMERCIAL	COMMERCIAL PRICE LIST

Line	CC	Material	Material Description	Qty	Unit Price	Discount	Extended Price
000010		<b>CCV-PACKAGES</b>	<b>30W P25 VHF Repeater</b>	<b>1.00</b>	<b>\$17,850.00</b>	<b>(\$3,570.00)</b>	<b>\$14,280.00</b>
000020	L1	VT-4E150-00-800	TRANSMITTR MT-4E,VHF136-174MHz	1.00			
000030	L1	VR-4E150-A0-000	RX,MT-4E,VHF136-174MHz,CLASS A	1.00			
000040	L1	APP-FIRM01-W-XX	FIRMWARE/MT4E RX/DIGITAL UPGRD	1.00			
000050	L1	APP-FIRM02-W-XX	FIRMWARE/MT4E TX/DIGITAL UPGRD	1.00			
000060	L1	SR-39-1	SUBRACK, 96 PIN + I/O,STANDARD	1.00			
000070	L1	SM-3-H0-014-00	SYSTEM REGULATOR,9-11 VDC,14HP	1.00			
000071	L1	AMP-4-150-30-00	AMPLIFIER/MT-4, 136-174MHz,30W	1.00			
000080	L1	A-PNL-AUX96-3	AUX CTRL EXTENDER + TERM BLOCK	1.00			
000090	L1	PSA-4P-1	POWER SUPPL/BACK PNL,12VDC/20A	1.00			
000100	L1	CBL223	CABLE/RF, RG223U	3.00			
000110	L1	CBLC46-12506025	Cable, RJ-45 to RJ45 25cm	1.00			
000120	L1	DUP-Q2330E	DUPLEXER,VHF,500KHz SEPARATION	1.00			

### SYSTEM TOTAL

Quantity:	1.00
Unit Price:	\$17,850.00
Subtotal:	\$17,850.00
Discount:	(\$3,570.00)
<b>TOTAL: (USD)</b>	<b>\$14,280.00</b>

### QUOTE TOTAL

NET:	\$14,280.00
OTHER:	
<b>TOTAL: (USD)</b>	<b>\$14,280.00</b>

DUNS # 201185543  
Danlels Electronics Ltd. dba Codan Radio Communications  
43 Erle Street  
Victoria, B.C.  
V8V 1P8 Canada

# QUOTE # 20038979

Toll Free: 1-800-664-4066  
Phone: 1-250-382-8268  
Email: [lmrsales@codanradio.com](mailto:lmrsales@codanradio.com)

## QUOTE

## CUSTOMER

**Quote #:** 20038979  
**Date:** 20 May 2020  
**From:** Richard Earl  
**Customer:** Temporary US  
**Export Controlled:** Yes

**Contact:** Mike Wink  
**Address:** South Lake County Fire Protection District  
21095 Hwy 175  
Middleton CA  
95461

**Opportunity #:** 21054  
**Quote Subject:** Repeater for South Lake County Fire

### 000010 SYSTEM CONFIGURATION FOR 30W P25 VHF REPEATER

#### 30W P25 VHF Repeater

System is configured as a AC powered 30W VHF P25 Full Duplex Repeater.

Includes duplexer with minimum 500Khz frequency seperation required.  
Includes Aux Panel to facilitate external connections.

Duplexer Size:  
Width 19"  
Depth 30.3"  
Length/Height 8.37"  
Weight - 45lbs

Frequencies required at time of order.

DUNS # 201185543  
Danlels Electronics Ltd. dba Codan Radio Communications  
43 Erie Street  
Victoria, B.C.  
V8V 1P8 Canada

# QUOTE # 20038979

Toll Free: 1-800-664-4066  
Phone: 1-250-382-8268  
Email: [lmrsales@codanradio.com](mailto:lmrsales@codanradio.com)

## QUOTE

**Quote #:** 20038979  
**Date:** 20 May 2020  
**From:** Richard Earl  
**Customer:** Temporary US  
**Export Controlled:** Yes  
  
**Opportunity #:** 21054  
**Quote Subject:** Repeater for South Lake County Fire

## CUSTOMER

**Contact:** Mike Wink  
**Address:** South Lake County Fire Protection District  
21095 Hwy 175  
Middletown CA  
95461

## TERMS

**Pricing** Valid for 90 Days. Notes: All prices quoted are exclusive of taxes. All cancelled orders will be subject to a 25% restocking fee.  
**Warranty** Standard Warranty of 3 years: parts and labour F.C.A Seattle, WA. Extended Warranties are available. Please contact Codan for pricing and details.  
**Payment Terms** 30 days from Invoice Date  
**Currency** USD  
**Shipping** F.C.A Seattle, WA. Unless otherwise specified. Codan Communications will ship courier ground.  
**Estimated Shipping** 7 to 9 weeks A.R.O. with frequency designations from quotation date. Earlier partial shipments may be available. Please contact the factory or your local representative listed below.

Richard Earl

## CC: COMPANY REPRESENTATIVE(S)

### Regional Sales Manager

**Name** Rick Felt  
**Company** Codan Radio Communications  
**Phone** +1 253 534 5361  
**Email** [Rick.Felt@codanradio.com](mailto:Rick.Felt@codanradio.com)

### Representative

**Name** Alan McIntosh  
**Company** Codan Radio Communications  
**Phone** +1250 414 6297  
**Email** [Alan.McIntosh@CodanComms.com](mailto:Alan.McIntosh@CodanComms.com)

*Codan's Standard Terms and Conditions of Supply and Product Warranty for all of Codan's standard products are available at <https://www.codanradio.com/terms-conditions> in adobe acrobat format. If you do not have acrobat reader, you can download it from the adobe website. If you are having difficulty viewing our Standard Terms and Conditions of Supply and Product Warranty, please call the telephone number set out in the relevant Order. All of Codan's Standard Terms and Conditions of Supply and Product Warranty apply to all Orders for the supply of Products by Codan to the Purchaser. No other terms or conditions will apply to an Order unless they have been expressly agreed to in writing and signed by a duly authorized representative of Codan.*

**From:** Alan McIntosh <[Alan.McIntosh@CodanComms.com](mailto:Alan.McIntosh@CodanComms.com)>  
**Sent:** Wednesday, May 6, 2020 10:26 AM  
**To:** Wink, Mike@CALFIRE <[Mike.Wink@fire.ca.gov](mailto:Mike.Wink@fire.ca.gov)>  
**Cc:** Rick Felt <[Rick.Felt@CodanComms.com](mailto:Rick.Felt@CodanComms.com)>; York, Brian@CALFIRE <[Brian.York@fire.ca.gov](mailto:Brian.York@fire.ca.gov)>  
**Subject:** RE: Daniels MT-4E Radio Price for South Lake County Fire

**Warning:** this message is from an external user and should be treated with caution.  
 Hi Mike,

I hope all is well today. I have reviewed your requirements and have one question, you provided information on the NWCG Standard Tone 7 configuration and I would like to understand if the repeater's receiver will need to have to ability to receive any one of these 7 tones and repeat out on the same tone at any time? Or will the receiver only need to "listen" for one of the tones (as programmed by your technician) at any given time and ignore all others?

I believe we can accommodate either scenario but the equipment will be a little different depending on your requirement.

Thanks and feel free to give me a call if you have any questions about this.

Regards,

**Alan McIntosh**

Technical Sales Representative

**P:** +1 250-414-6297  
**TF:** +1 800-664-4066 ext 297  
**M:** +1 250-889-7901  
**E:** [alan.mcintosh@codancomms.com](mailto:alan.mcintosh@codancomms.com)

<https://codancomms.com/lmr>

Daniels Electronics Ltd doing business as Codan Communications.

---

**From:** Wink, Mike@CALFIRE <[Mike.Wink@fire.ca.gov](mailto:Mike.Wink@fire.ca.gov)>  
**Sent:** Saturday, May 02, 2020 5:55 PM  
**To:** Alan McIntosh <[Alan.McIntosh@CodanComms.com](mailto:Alan.McIntosh@CodanComms.com)>  
**Cc:** Rick Felt <[Rick.Felt@CodanComms.com](mailto:Rick.Felt@CodanComms.com)>; York, Brian@CALFIRE <[Brian.York@fire.ca.gov](mailto:Brian.York@fire.ca.gov)>  
**Subject:** Re: Daniels MT-4E Radio Price for South Lake County Fire

**[EXTERNAL]** This email was sent from outside of the Codan Group. Use caution when opening attachments or links from unknown senders.

Good afternoon, please see answers below. Mike

- 
- x1 Daniels MT-4E Radio
- x1 30 watt internal amp
- x1 Small rack for radio, amp, power supply
- Cavity Filters

110v power is available at the site.

It will be used in the 155.02500 frequency Range. Lake County "RED" for Fire/Rescue/EMS

XLK RED	Rx 155.02500	Rx 88.5	Tx 154.05500	OST 000.0	High Power	Narrow Band	Lake County
---------	-----------------	------------	-----------------	--------------	---------------	----------------	-------------

The 30 watt power should be the internal spec. We will need Cavity Filters to support the close pair of Tx and Rx.  
 Thanks, Mike

Possible NWCG Standard Tone 7 configuration when programmed.

We have a technician to program it, just need the components.

We are only considering the Daniels Radio, please do not send alternatives.

If the test repeater is successful, the purchase could be approved in the next 90 days. Waiting on the testing data.

The South Lake County Fire Protection District needs to add a radio repeater in their area to improve HT Radio communications. A site is being tested with a test repeater soon. We want to get the radio purchased so when the process is complete and approved we are ready to go. All the best, Mike

<https://www.radioreference.com/apps/db/?ctid=199>

[Lake County, California \(CA\) Scanner Frequencies and Radio Frequency Reference](#)

Scanner Frequencies and Radio Frequency Reference for Lake County, California (CA)

[www.radioreference.com](http://www.radioreference.com)

**From:** Alan McIntosh <[Alan.McIntosh@CodanComms.com](mailto:Alan.McIntosh@CodanComms.com)>  
**Sent:** Monday, March 23, 2020 9:02 AM  
**To:** Wink, Mike@CALFIRE <[Mike.Wink@fire.ca.gov](mailto:Mike.Wink@fire.ca.gov)>  
**Cc:** Rick Felt <[Rick.Felt@CodanComms.com](mailto:Rick.Felt@CodanComms.com)>  
**Subject:** FW: Daniels MT-4E Radio Price for South Lake County Fire

**Warning:** this message is from an external user and should be treated with caution.  
 Hi Mike,

Thanks for the RFQ. I have a few questions for you:

- 1. Is this Analog or P25 digital?

P25

- 1. Based on your description, this appears to be a repeater (not a base station). Can you please confirm?

Repeater

- 1. If a repeater, would you like a duplexer quoted or will you be supplying your own? If Codan is quoting the duplexer can you please send me the transmit and receive frequencies or the frequency separation?

Yes, need duplexer.

It will be used in the 155.02500 frequency Range. Lake County "RED" for Fire/Rescue/EMS

XLK RED	Rx 155.02500	Rx 88.5	Tx 154.05500	OST 000.0	High Power	Narrow Band	Lake County
---------	-----------------	------------	-----------------	--------------	---------------	----------------	-------------

- 1. You mentioned a "NWCG Standard Tone 7 configuration", can you tell me more about that or send me a web link with more information so I can have a look?

The California Travel Net map is shown on page 84. CONTINUOUS TONE CONTROL SELECTION SYSTEM (CTCSS) CTCSS encoding provides continuous sub-audible tone to access mobile relays (repeaters) and provide access to receive tone protected radios. Tone 1 110.9 Hz Tone 9 100.0 Hz Tone 2 123.0 Hz Tone 10 107.2 Hz Tone 3 131.8 Hz Tone 11 114.8 Hz Tone 4 136.5 Hz Tone 12

127.3 Hz Tone 5 146.2 Hz Tone 13 141.3 Hz Tone 6 156.7 Hz Tone 14 151.4 Hz Tone 7 167.9 Hz Tone 15 162.2 Hz Tone 8 103.5 Hz Tone 16 192.8 Hz \*NOTE: The above tones are the standard approved by CDF, Firescope Communications, BLM, BIA and the USFS.

1. Would you like us to include an Aux Panel for convenient access to backplane signals in our quote?

Yes

1. Would you like us to include maintenance items for the radio in our quote such as the USB programming cable or do you already have this equipment?

No

1. Is there a certain contract you prefer to use when purchasing this equipment such as NASPO California or GSA?

No

1. I understand the first purchase would be used for testing. Would you potentially be purchasing more if the test is successful? If so, how many?

No, just this one purchase

I look forward to hearing back from you. Please don't hesitate to call me if you would like to discuss any of these points.

Regards,

**Alan McIntosh**

Technical Sales Representative

**P:** +1 250 414 6297

**TF:** +1 800 664 4066 ext 297

**M:** +1 250-889-7901

**E:** [alan.mcintosh@codancomms.com](mailto:alan.mcintosh@codancomms.com)

<https://codancomms.com/lmr>

Daniels Electronics Ltd doing business as Codan Communications.

**From:** Wink, Mike@CALFIRE <[Mike.Wink@fire.ca.gov](mailto:Mike.Wink@fire.ca.gov)>

**Sent:** Sunday, March 22, 2020 1:47 PM

**Subject:** Daniels MT-4E Radio Price for South Lake County Fire

**[EXTERNAL] This email was sent from outside of the Codan Group. Use caution when opening attachments or links from unknown senders.**

Good afternoon Radio Vendor. I am requesting a price for:

- x1 Daniels MT-4E Radio
- x1 30 watt amp to go with it
- x1 Small rack for radio, amp, power supply

110v power is available at the site.

It will be used in the 155.02500 frequency Range. Lake County "RED" for Fire/Rescue/EMS

Possible NWCG Standard Tone 7 configuration when programmed.

We have a technician to program it, just need the components.

We are only considering the Daniels Radio, please do not send alternatives.

If the test repeater is successful, the purchase could be approved in the next 90 days. Waiting on the testing data.

The South Lake County Fire Protection District needs to add a radio repeater in their area to improve HT Radio communications. A site is being tested with a test repeater soon. We want to get the radio purchased so when the process is complete and approved we are ready to go. All the best, Mike

<https://www.radioreference.com/apps/db/?ctid=199>

## [Lake County, California \(CA\) Scanner Frequencies and Radio Frequency Reference](https://www.radioreference.com/apps/db/?ctid=199)

Scanner Frequencies and Radio Frequency Reference for Lake County, California (CA)

[www.radioreference.com](https://www.radioreference.com)

### **Mike Wink**

**Battalion Chief**

**Middletown Battalion**

### **South Lake County Fire Protection District**

21095 Hwy 175 - P.O.Box 1360

Middletown, Ca. 95461

Office: 707.987-3089 ext 1

Cell: 707.889.4225

Fax: 707.987.9478

Email [Mike.Wink@fire.ca.gov](mailto:Mike.Wink@fire.ca.gov)

---

This email and any attachments to it are confidential and may be the subject of legal professional privilege. If you are not the intended recipient of this email, then you must not use, disclose, copy or distribute any part of this email. If you have received this email in error, please inform the sender and then delete the email and any attachments from your system. All rights in this email and any attached documents or files are expressly reserved. We use virus scanning software, however we exclude all liability arising from any computer viruses, hoax or phishing emails or otherwise arising in connection with this email or any attachment to it. Any views expressed in this email are those of the individual sender only, unless expressly stated to be those of Codan Limited or its related entities.

---

---

This email and any attachments to it are confidential and may be the subject of legal professional privilege. If you are not the intended recipient of this email, then you must not use, disclose, copy or distribute any part of this email. If you have received this email in error, please inform the sender and then delete the email and any attachments from your system. All rights in this email and any attached documents or files are expressly reserved. We use virus scanning software, however we exclude all liability arising from any computer viruses, hoax or phishing emails or otherwise arising in connection with this email or any attachment to it. Any views expressed in this email are those of the individual sender only, unless expressly stated to be those of Codan Limited or its related entities.

---

---

This email and any attachments to it are confidential and may be the subject of legal professional privilege. If you are not the intended recipient of this email, then you must not use, disclose, copy or distribute any part of this email. If you have received this email in error, please inform the sender and then delete the email and any attachments from your system. All rights in this email and any attached documents or files are expressly reserved. We use virus scanning software, however we exclude all liability arising from any computer viruses, hoax or phishing emails or otherwise arising in connection with this email or any attachment to it. Any views expressed in this email

## Estimate 5224 from Sandy's Communications

Sandy's Communications <jeff@sandyscomm.com>

Thu 7/16/2020 9:41 AM

To: Wink, Mike@CALFIRE <Mike.Wink@fire.ca.gov>

Cc: jeff@sandyscomm.com <jeff@sandyscomm.com>

 1 attachments (67 KB)

Est\_5224\_from\_Sandys\_Communications\_7396.pdf;

Warning: this message is from an external user and should be treated with caution.

Dear Chief Wink:

Please review the attached estimate. Feel free to contact me if you have any questions.

I look forward to working with you.

Sincerely,

Jeffrey Samuels  
Sandy's Communications  
866.993.9011



# Sandy's Communications

PO Box 950489  
Mission Hills, CA 91395  
Motorola Authorized Dealer

# Estimate

Date	Estimate #
7/16/2020	5224

Name / Address
CalFire South Lake Co Mike Wink 21095 Hwy 175 - P.O.Box 1360 Middletown, CA 95461

Terms	Project
Net 45	

Item	Description	Qty	Unit	Extended
Misc	Codan VT-4E150-00-800 TRANSMITTER, MT-4E, VHF136-174, Analog	1	1,915.00	1,915.00T
Misc	Codan VR-4E150-A0-000 RX, MT-4E, VHF136-174, CLASS A, Analog	1	2,315.00	2,315.00T
Misc	Codan AMP-4-150-30-00 AMP-4 VHF 30 WATT POWER AMPLIFIER	1	1,345.00	1,345.00T
Misc	Codan SM-3-H0-014-00 SYSTEM REGULATOR, 9-11 VDC, 14HP	1	790.00	790.00T
Misc	Codan SR-39-1 SUBRACK/MOTHERBOARD, 96PIN+I/O	1	995.00	995.00T
Misc	Codan PSA-4P-1 POWER SUPPLY/BACK PNL, 12VDC/20A	1	595.00	595.00T
Misc	Codan CBLC46-12506025 Cable, RJ-45 to RJ45 25cm	1	44.00	44.00T
Misc	Codan RR-1363-BT 36.75" x 19" Open Rack with Chassis Base, Black	1	222.00	222.00T
Misc	Chatsworth 46053-231 3' (0.9 m) 17U 19" Rack Duplexer, Sinclair, VHF. Rack Mount Pass/Reject, 350W Max TX, 500KHz Minimum Separation. Includes tuning to customer frequencies.	1	411.00	411.00T
Q2220E-1	Jumper Cable, RG142, Repeater to Duplexer, 3 Foot. One each for transmitter & receiver.	1	1,215.00	1,215.00T
Jumper		2	38.00	76.00T
FedEx Ground	Federal Express Ground Shipping	1	50.00	50.00

<b>Subtotal</b>	\$9,973.00
<b>Sales Tax (7.25%)</b>	\$719.42
<b>Total</b>	\$10,692.42

*FILTERS + \$5,000.00  
INCOMPLETE*

Phone #	Fax #	E-mail	Web Site
866.993.9011	818.993.8619	jeff@sandyscomm.com	http://www.sandyscomm.com

**RE: Daniels MT-4E Radio Price for South Lake County Fire**

Mark Champ <mchamp@2viscom.com>

Thu 4/9/2020 1:42 PM

To: Wink, Mike@CALFIRE <Mike.Wink@fire.ca.gov>

Cc: Sharon Asbe <sasbe@2viscom.com>

📎 1 attachments (95 KB)

2020-04-09 Codan VHF 30w Repeater -.xls;

**Warning:** this message is from an external user and should be treated with caution.

Dear Mike,

Please find attached a proposal for a Codan (Daniels) VHF repeater per your request. Let me know if I need to make any adjustments in hardware after your RF testing is complete.

Many Regards,

Mark A. Champ  
Sales Manager

**Vision Communications**

1770 Neptune Drive  
San Leandro, CA. 94577  
Office: (510) 346-0300 Cell: (408) 461-0445  
mchamp@2viscom.com  
[www.2viscom.com](http://www.2viscom.com) [www.viscompse.com](http://www.viscompse.com)

---

**From:** Wink, Mike@CALFIRE <[Mike.Wink@fire.ca.gov](mailto:Mike.Wink@fire.ca.gov)>  
**Sent:** Thursday, April 02, 2020 12:44 AM  
**To:** Bob Moayeri <[bmoayeri@2viscom.com](mailto:bmoayeri@2viscom.com)>  
**Subject:** Daniels MT-4E Radio Price for South Lake County Fire

Good afternoon Radio Vendor. I am requesting a price for:

- x1 Daniels MT-4E Radio
- x1 30 watt internal amp
- x1 Small rack for radio, amp, power supply
- Cavity Filters

110v power is available at the site.

It will be used in the 155.02500 frequency Range. Lake County "RED" for Fire/Rescue/EMS

XLK RED	Rx 155.02500	Rx 88.5	Tx 154.05500	OST 000.0	High Power	Narrow Band	Lake County
---------	-----------------	------------	-----------------	--------------	---------------	----------------	-------------

The 30 watt power should be the internal spec. We will need Cavity Filters to support the close pair of Tx and Rx. Thanks, Mike

Possible NWCG Standard Tone 7 configuration when programmed.

We have a technician to program it, just need the components.

We are only considering the Daniels Radio, please do not send alternatives.

If the test repeater is successful, the purchase could be approved in the next 90 days. Waiting on the testing data.

The South Lake County Fire Protection District needs to add a radio repeater in their area to improve HT Radio communications. A site is being tested with a test repeater soon. We want to get the radio purchased so when the process is complete and approved we are ready to go. All the best, Mike

<https://www.radioreference.com/apps/db/?ctid=199>

## [Lake County, California \(CA\) Scanner Frequencies and Radio Frequency Reference](https://www.radioreference.com/apps/db/?ctid=199)

Scanner Frequencies and Radio Frequency Reference for Lake County, California (CA)

[www.radioreference.com](https://www.radioreference.com)

***Mike Wink***

**Battalion Chief**

**Middletown Battalion**

***South Lake County Fire Protection District***

**21095 Hwy 175 - P.O.Box 1360**

**Middletown, Ca. 95461**

**Office: 707.987-3089 ext 1**

**Cell: 707.889.4225**

**Fax: 707.987.9478**

**Emial [Mike.Wink@fire.ca.gov](mailto:Mike.Wink@fire.ca.gov)**

VISION COMMUNICATIONS  
**CUSTOMER QUOTE**

**BILL TO:**

COMPAN SOUTH LAKE COUNTY FIRE PROTECTION DISTRICT  
 ATTENTION MIKE WINK, BATTALION CHIEF  
 ADDRESS: 21075 HWY 175 , P.O.BOX 1360  
 CITY: MIDDLETOWN, CA. 95461  
 PHONE: 707-987-3089 X 1 CELL

**SHIP TO:**

COMPAN SAME  
 ATTENTION:  
 ADDRESS:  
 CITY:  
 PHONE:  
 DEPT:  
 STATE: CA  
 FAX:

[MIKE.WINK@FIRE.CA.GOV](mailto:MIKE.WINK@FIRE.CA.GOV)

QTY	PART NUMBER	EQUIPMENT DESCRIPTION	UNIT COST	EXTENDED COST
1	LMR-RPTR30-VPKA	CODAN VHF, 30W, MT4E REPEATER PACKAGE WITH CLASS A HIGH SPECIFICATION RECEIVER	\$ 6,682.51	\$ 6,682.51
1	LMR-RPTR30-ACDC	CODAN 20A, HIGH POWER AC POWER SUPPLY	\$ 518.65	\$ 518.65
1	LMR-RPTR30-VDUP2	CODAN NARROW CHANNEL, HIGH POWER DUPLEXER	\$ 3,188.98	\$ 3,188.98
1	LMR-RPTR30-ES1	CODAN 19" RACK CABINET WITH LOCKING DOORS, 28 RU	\$ 1,031.89	\$ 1,031.89

*NO FILTERS  
 NOT COMPATIBLE  
 NOT COMPATIBLE*

**SPECIAL INSTRUCTIONS:**

ALL ORDERS ARE SUBJECT TO 25% RESTOCKING FEE IF CANCELLED OR RETURNED.

QUOTE IS VALID FOR 30 DAYS \*\* NET 10 DAYS

<b>SUBTOTAL</b>	<b>\$</b>	<b>11,422.03</b>
TAX 7.25%	\$	828.10
SHIPPING	\$	228.44
<b>LABOR</b>	<b>\$</b>	<b>-</b>
<b>TOTAL DUE</b>	<b>\$</b>	<b>12,478.57</b>

NOTE: This quote is intended only for the use of the person/s to whom it is addressed and may contain information that is privileged, confidential, and protected from disclosure under applicable law. If the reader of this message is not the intended recipient, you are hereby notified that any dissemination, distribution or copying of this communication is strictly prohibited.

COMPLETED BY	DATE	CONTACT INFORMATION	SIGNATURE	PO #
MARK A. CHAMP	4/9/2020	OFFICE: (510) 346-0300 MOBILE: (408) 461-0445 mchamp@2viscom.com		

**THANK YOU FOR CHOOSING VISION COMMUNICATIONS, CO.**

VISION COMMUNICATIONS CO

1770 Neptune Drive San Leandro, CA 94577

PHONE (510) 346-0300 FAX (510) 346-8474



**South Lake County Fire Protection District**  
— in cooperation with —  
**California Department of Forestry and Fire Protection**

---

P.O. Box 1360 Middletown, CA 95461 - (707) 987-3089

**DATE:** December 12, 2020  
**TO:** Board of Directors  
**FROM:** Gloria Fong  
Staff Services Analyst  
**SUBJECT:** Resolution No. 2020-21-11, A Resolution Establishing and Appropriating Over-Realized / Unanticipated Revenues from Assistance to Firefighters Grant (AFG) and Fire Mitigation Fees for Purchase of Self-Contained Breathing Apparatus Units (SCBAs)

Subject resolution is provided for Board's consideration and approval. This resolution establishes and appropriates the AFG funds and transfers, establishes and appropriates fire mitigation fee funds.

As mentioned in prior meetings all the Lake County fire districts applied for grant to purchase SCBA units. The application is Exhibit D of the resolution with Exhibit A, as the Memorandum of Understanding detailing Northshore Fire Protection District as the lead agency and the four fire districts as subgrantees.

The grant purchases 35 SCBA units as detailed in Exhibit B. An additional 5 with upgrades were purchased to meet the 40 unit need for South Lake County Fire Protection District, and this invoice is included under Exhibit C.

Attachments: 1) subject resolution

**BOARD OF DIRECTORS, SOUTH LAKE COUNTY FIRE PROTECTION DISTRICT**  
**COUNTY OF LAKE, STATE OF CALIFORNIA**

**RESOLUTION NO. 2020-21- 11**

**A RESOLUTION ESTABLISHING AND APPROPRIATING OVER-REALIZED /  
UNANTICIPATED REVENUES FROM ASSISTANCE TO FIREFIGHTERS GRANT (AFG)  
AND FIRE MITIGATION FEES FOR PURCHASE OF  
SELF-CONTAINED BREATHING APPARATUS UNITS (SCBAs)**

1           **WHEREAS, GOVERNMENT CODE 29130**, provides that over-realized unanticipated  
2 revenue may be available for specific appropriation by a four-fifths vote of the Board at a noticed  
3 public hearing held as part of any regular or special meeting of which all members have had  
4 reasonable notice; and,

5           **WHEREAS**, Assistance to Firefighter Grant Memorandum of Understanding attached hereto  
6 as “Exhibit A” is made as part application for Fiscal Year 2019 AFG through the Federal Emergency  
7 Management Agency attached hereto as “Exhibit D”; and,

8           **WHEREAS**, South Lake County Fire Protection District is one of the subgrantees, awarded  
9 in the AFG, for the purchase of SCBAs invoice number 228081 and afforded same cost five (5)  
10 more SCBAs with upgraded attached hereto as “Exhibit C.”

11           **NOW, THEREFORE, BE IT RESOLVED THAT** the Board of Directors of the South Lake  
12 County Fire Protection District accepts award attached hereto as “Exhibit B” and directs the  
13 unanticipated / over-realized revenue

14           sum of \$193,929 be appropriated

15                   From Fund No. 357, Account No. 9557-456.56-30

16                   To Fund No. 357, Account No. 9557-795.62-74

17           the sum of \$ 75,466 be appropriated

18                   From Fund no. 366, Account No. 0000-502.81-23

19                   To Fund no. 357, Account No. 9557-502.81-22

20                   To Fund no. 357, Account No. 9557-795.62-74

21           **THIS RESOLUTION** was introduced and adopted by the Board of Directors of the South  
22 Lake County Fire Protection District at a Regular Meeting on the 15<sup>th</sup> day of December, 2020  
23 by the following vote:

AYES:

NOES:

ABSENT OR NOT VOTING:

SOUTH LAKE COUNTY  
FIRE PROTECTION DISTRICT

\_\_\_\_\_  
MADELYN MARTINELLI  
President, Board of Directors

ATTEST: \_\_\_\_\_  
Gloria Fong  
Clerk to the Board of Directors

**AFG SCBA GRANT**

**Memorandum of Understanding**

1  
2  
3  
4  
5       **THIS AGREEMENT** is entered into this Wednesday day of July 22nd 2020, which date is  
6 enumerated for purposes of reference only, by and between the NORTSHORE FIRE PROTECTION  
7 DISTRICT, a political subdivision of the State of California, hereinafter referred to as "NFPD", and  
8 LAKE COUNTY FIRE PROTECTION DISTRICT, LAKEPORT FIRE PROTECTION DISTRICT,  
9 KELSEYVILLE FIRE PROTECTION DISTRICT, SOUTH LAKE COUNTY FIRE PROTECTION  
10 DISTRICT and LAKE PILLSBURY FIRE all special districts, hereinafter referred to as  
11 "SUBGRANTEE'S's."

12       **WHEREAS**, NFPD, as the lead agency for the Lake County, CA Fire Operational Area, has  
13 applied for, an Assistance Fire Grant through the FEDERAL EMERGENCY MENAGEMENT  
14 AGENCY, to enhance the agencies breathing apparatus, hereinafter referred to as "the grant", as set  
15 forth in the grant documents that are incorporated herein by reference.

16       **WHEREAS**, the terms of the grant require that NFPD use certain grant funds to purchase  
17 breathing apparatus equipment that will be transferred to SUBGRANTEE'S to be used for grant  
18 purposes.

19       **NOW, THEREFORE, IT IS MUTUALLY AGREED AS FOLLOWS:**

20       1. NFPD shall transfer to SUBGRANTEE'S the equipment, as specified in Exhibit B  
21 hereto, which is incorporated herein by reference. If the grant requires NFPD to transfer to  
22 SUBGRANTEE'S equipment, that NFPD has not yet acquired, NFPD shall transfer said equipment, to  
23 SUBGRANTEE'S as soon after acquisition by NFPD as is reasonably practicable.

24       2. Throughout its useful life, SUBGRANTEE'S shall use any equipment, acquired with  
25 grant funds only for those purposes permitted under the terms of the grant, and shall make it available  
26 for mutual aid response.

27       3. SUBGRANTEE'S shall exercise due care to preserve and safeguard equipment acquired  
28 with grant funds from damage or destruction and shall provide regular maintenance and repairs for said



1 equipment as are necessary, in order to keep said equipment in continually good working order. Such  
2 maintenance and servicing shall be the sole responsibility of the SUBGRANTEE'S, who shall pay for  
3 material and labor costs for any maintenance and repair of the said equipment throughout the life of the  
4 said equipment.

5 4. SUBGRANTEE'S shall assume all continuation costs of said equipment, to include but  
6 not limited to upgrades, licenses and renewals of said equipment.

7 5. If SUBGRANTEE'Ss have accepted equipment and/or attended specialized training, the  
8 SUBGRANTEE'S shall be available and respond to any call out situations with necessary equipment  
9 and personnel within a reasonable amount of time as determined by agency requesting the mutual aid.

10 6. If equipment acquired with grant funds becomes obsolete or unusable, SUBGRANTEE'S  
11 shall notify NFPD of such condition. SUBGRANTEE'S shall transfer or dispose of grant-funded  
12 equipment only in accordance with the instructions of NFPD.

13 7. SUBGRANTEE'S agrees to indemnify, defend and save harmless NFPD and their  
14 elected and appointed officials, officers, agents and employees from any and all claims and losses  
15 accruing or resulting to any and all contractors, subcontractors, laborers, and any other person, firm or  
16 corporation furnishing or supplying work services, materials or supplies in connection with  
17 SUBGRANTEE'S's performance of this Agreement, hereto, and from any and all claims and losses  
18 accruing or resulting to any person, firm, or corporation who may be injured or damaged by  
19 SUBGRANTEE'S in the performance of this Agreement.

20 8. NFPD shall have the ability to inventory equipment at any time necessary to comply with  
21 grant requirements. Sufficient notification shall be given.

22 9. By executing this Agreement, SUBGRANTEE'S agrees to comply with and be fully  
23 bound by all applicable provisions. SUBGRANTEE'S shall notify NFPD immediately upon discovery  
24 that it has not abided or no longer will abide by any applicable provisions.

25 10. SUBGRANTEE'S and NFPD shall be subject to examination and audit by the State  
26 Auditor General with respect to this Agreement for a period of five years after grant closeout.

1 11. No alteration or variation of the terms of this Agreement shall be valid unless made in  
2 writing and signed by duly authorized representatives of the parties hereto, and no oral understanding or  
3 agreement not incorporated herein shall be binding on any of the parties hereto.

4 12. SUBGRANTEE'S may not assign this Agreement in whole or in part without the express  
5 written consent of NFPD.

6 13. For a period of five years after grant closeout hereunder or until all claims related to this  
7 Agreement are finally settled, whichever is later, SUBGRANTEE'S shall preserve and maintain all  
8 documents, papers and records relevant to the work performed or property or equipment acquired in  
9 accordance with this Agreement. For the same time period, SUBGRANTEE'S shall make said  
10 documents, papers and records available to NFPD and the agency from which NFPD received grant  
11 funds or their duly authorized representative(s), for examination, copying, or mechanical reproduction  
12 on or off the premises of SUBGRANTEE'S, upon request during usual working hours.

13 14. SUBGRANTEE'S shall provide to NFPD all records and information requested by  
14 NFPD for inclusion in quarterly reports and such other reports or records as NFPD may be required to  
15 provide to the agency from which NFPD received grant funds or other persons or agencies.

16 15. NFPD may terminate this Agreement and be relieved of the payment of any consideration  
17 to SUBGRANTEE'S if a) SUBGRANTEE'S fails to perform any of the covenants contained in this  
18 Agreement, at the time and in the matter herein provided, or b) NFPD loses funding under the grant. In  
19 the event of termination, NFPD may proceed with the work in any manner deemed proper by NFPD.

20 16. SUBGRANTEE'S and its agents and employees shall act in an independent capacity in  
21 the performance of this Agreement, and shall not be considered officers, agents or employees of NFPD  
22 or of the agency from which NFPD received grant funds.

23  
24  
25  
26  
27  
28

1           **IN WITNESS WHEREOF**, the parties have executed this Agreement in the County of Lake,  
2 State of California.

3 APPROVED AS TO FORM:

4 Northshore Fire Protection District  
5 By: Mike Ciancio- Fire Chief

6 

7 DATED: 7-22-2020

8 Lake County Fire Protection District  
9 By: Willie Sapeta- Fire Chief

10 

11 DATED: 7/22/2020

12  
13 Lakeport Fire Protection District  
14 By: Rick Bergem- Fire Chief

15 

16 DATED: 7-22-20

17 Kelseyville Fire Protection District  
18 By: Joe Huggins- Fire Chief

19 

20 DATED: 7/22/2020

21 South Lake County Fire Protection District  
22 By: Paul Duncan- Fire Chief

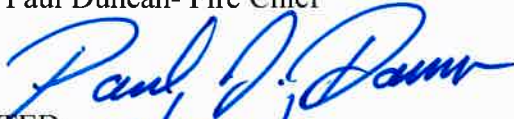
23 

24 DATED: 7/22/20

25 Lake Pillsbury Fire  
26 By: Larry Thompson- Fire Chief

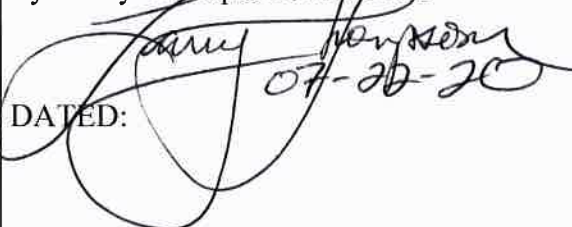
27   
28 DATED: 07-20-20

## Award Letter

U.S. Department of Homeland Security  
Washington, D.C. 20472

Mike Ciancio  
NORTSHORE FIRE PROTECTION DISTRICT  
6257 7TH AVE P.O. BOX 1199  
LUCERNE, CA 95458



EMW-2019-FG-06245

Dear Mike Ciancio,

Congratulations on behalf of the Department of Homeland Security. Your application submitted for the Fiscal Year (FY) 2019 Assistance to Firefighters Grant (AFG) Grant funding opportunity has been approved in the amount of \$886,532.40 in Federal funding. As a condition of this grant, you are required to contribute non-Federal funds equal to or greater than 10.0% of the Federal funds awarded, or \$88,653.24 for a total approved budget of \$975,185.64. Please see the FY 2019 AFG Notice of Funding Opportunity for information on how to meet this cost share requirement.

Before you request and receive any of the Federal funds awarded to you, you must establish acceptance of the award through the FEMA Grants Outcomes (FEMA GO) system. By accepting this award, you acknowledge that the terms of the following documents are incorporated into the terms of your award:

- Summary Award Memo - included in this document
- Agreement Articles - included in this document
- Obligating Document - included in this document
- 2019 AFG Notice of Funding Opportunity (NOFO) - incorporated by reference

Please make sure you read, understand, and maintain a copy of these documents in your official file for this award.

Sincerely,

A handwritten signature in black ink, appearing to read "Christopher Logan". The signature is written in a cursive style with a long horizontal stroke at the end.

Christopher Logan  
Acting Assistant Administrator  
Grant Programs Directorate

## Summary Award Memo

**Program:** Fiscal Year 2019 Assistance to Firefighters Grant  
**Recipient:** NORTSHORE FIRE PROTECTION DISTRICT  
**DUNS number:** 786142240  
**Award number:** EMW-2019-FG-06245

### Summary description of award

The purpose of the Assistance to Firefighters Grant program is to protect the health and safety of the public and firefighting personnel against fire and fire-related hazards. After careful consideration, FEMA has determined that the recipient's project or projects submitted as part of the recipient's application and detailed in the project narrative as well as the request details section of the application - including budget information - was consistent with the Assistance to Firefighters Grant Program's purpose and was worthy of award.

Except as otherwise approved as noted in this award, the information you provided in your application for FY2019 Assistance to Firefighters Grants funding is incorporated into the terms and conditions of this award. This includes any documents submitted as part of the application.

### Amount awarded

The amount of the award is detailed in the attached Obligating Document for Award.

The following are the budgeted estimates for object classes for this award (including Federal share plus your cost share, if applicable):

<b>Object Class</b>	<b>Total</b>
Personnel	\$0.00
Fringe benefits	\$0.00
Travel	\$0.00
Equipment	\$909,264.00
Supplies	\$0.00
Contractual	\$0.00
Construction	\$0.00
Other	\$65,921.64
Indirect charges	\$0.00
Federal	\$886,532.40
Non-federal	\$88,653.24
<b>Total</b>	<b>\$975,185.64</b>
Program Income	\$0.00

### **Approved scope of work**

After review of your application, FEMA has approved the below scope of work. Justifications are provided for any differences between the scope of work in the original application and the approved scope of work under this award. You must submit scope or budget revision requests for FEMA's prior approval, via an amendment request, as appropriate per 2 C.F.R. § 200.308 and the FY2019 AFG NOFO.

#### **Approved request details:**

### **Personal Protective Equipment (PPE)**

**SCBA: SCBA Unit includes: Harness/Backpack, Face Piece and 2 cylinders**

DESCRIPTION

System includes: (1) Scott X3 PRO Air-pak. 4500psi with CGA Connection QD Regulator with Rectus Connector, Dual UEBSS (Buddy Breathing) , PASS w/Pak-tracker, With Standard Waist Belt. (1) 45 minute, Carbon Wrapped Cylinder with Valve, 4500psi Banded Identifier included @ No Charge. (1) AV3000 HT Facepiece with Epic Voice Amp Bracket. (1) Epic Voice Amp Additional Carbon Wrapped Cylinder with Valve, 45 minute, 4500 psi.

	QUANTITY	UNIT PRICE	TOTAL	BUDGET CLASS
Cost 1	160	\$5,682.90	\$909,264.00	Equipment

CHANGE FROM APPLICATION

Cost 1 **Budget class** from **Personnel** to **Equipment**

JUSTIFICATION

This award reflects a change in Budget class from Personnel to Equipment.

**Additional funding**

DESCRIPTION

Additional Funding is the Sales Tax of 7.25% for the purpose of SCBA units.

	QUANTITY	UNIT PRICE	TOTAL	BUDGET CLASS
Cost 1	1	\$65,921.64	\$65,921.64	Other

SCBA District Portion

"Exhibit B"

Grant Awarded Amount	\$886,532.40
District Portion	\$88,653.24
Total	\$975,185.64

Grant Portion Distribution			
Disticts	Pack Amount	Percent	
Lakeport Fire	29	18%	\$160,684.00
Northshore Fire	33	21%	\$182,847.31
Lake County Fire	27	17%	\$149,602.34
Kelseyville Fire	23	14%	\$127,439.03
Southlake Fire	35	22%	\$193,928.96
Lake Pillsbury	13	8%	\$72,030.76
	160	100%	\$ 886,532.40

District	District Contribution 10%	
Lakeport Fire	\$	16,290.25
Northshore Fire	\$	16,290.25
Lake County Fire	\$	16,290.25
Kelseyville Fire	\$	16,290.25
Southlake Fire	\$	16,290.25
Lake Pillsbury	\$	7,202.00
Total	\$	88,653.25

Combined amounts for each district	
Lakeport Fire	\$176,974.25
Northshore Fire	\$199,137.56
Lake County Fire	\$165,892.59
Kelseyville Fire	\$143,729.28
Southlake Fire	\$210,219.21
Lake Pillsbury	\$79,232.75
Total	\$ 975,185.64



County of Lake  
Office of the Auditor-Controller  
Inter-Department Charges (IDC)  
Inter-Department Services (IDS)

I. REQUEST IS HEREBY submitted to the Auditor-Controller to prepare Journal Entry:

DEPARTMENT TO BE REIMBURSED Lake County Fire Protection District 9552 for work performed.  
(Budget Title) (Budget No.)

Description #1: SBCA Grant portion distribution Project #: \_\_\_\_\_

Description #2: FEMA -AFG grant

Approved by: \_\_\_\_\_ (Date)  
(Receiving/Authorized Signature)

II. DEPARTMENT TO BE CHARGED: Northshore Fire \_\_\_\_\_ for work performed.  
(Budget Title) (Budget No.)

Description #1: SBCA Grant portion distribution Project #: \_\_\_\_\_

Description #2: FEMA -AFG grant

Approved by:  \_\_\_\_\_ (Date)  
(Authorized Signature) 

III. Detail prepared by Department requesting Reimbursement.  
Detail verified by Department to be charged.

	FUND 000	DEPT 0000	ACCOUNT 000.00-00	DEBIT	CREDIT
I.	355	9555	453.56-30	149,602.34	
II.	352	9552	453.56-30		149,602.34

IV. Auditor Controller only:

Review of Sections I, II, & III is determined to be complete, documented and approved by authorized signatures.

Journal Entry Number: \_\_\_\_\_ Date: \_\_\_\_\_

Prepared by: \_\_\_\_\_ (Deputy)

County of Lake  
Office of the Auditor-Controller  
Inter-Department Charges (IDC)  
Inter-Department Services (IDS)

I. REQUEST IS HEREBY submitted to the Auditor-Controller to prepare Journal Entry:

DEPARTMENT TO BE REIMBURSED Lakeport Fire 9554 for work performed.  
(Budget Title) (Budget No.)

Description #1: SBCA Grant portion distribution Project #: \_\_\_\_\_

Description #2: FEMA -AFG grant

Approved by: \_\_\_\_\_ (Receiving/Authorized Signature) \_\_\_\_\_ (Date)

II. DEPARTMENT TO BE CHARGED: Northshore Fire \_\_\_\_\_ for work performed.  
(Budget Title) (Budget No.)

Description #1: SBCA Grant portion distribution Project #: \_\_\_\_\_

Description #2: FEMA -AFG grant

Approved by: *C. Jimenez* (Authorized Signature) *12/11/2008* (Date)

III. Detail prepared by Department requesting Reimbursement.

Detail verified by Department to be charged.

	FUND 000	DEPT 0000	ACCOUNT 000.00-00	DEBIT	CREDIT
I.	355	9555	453.56-30	160,684.00	
II.	354	9554	453.56-30		160,684.00

IV. Auditor Controller only:

Review of Sections I, II, & III is determined to be complete, documented and approved by authorized signatures.

Journal Entry Number: \_\_\_\_\_ Date: \_\_\_\_\_

Prepared by: \_\_\_\_\_ (Deputy)

County of Lake  
Office of the Auditor-Controller  
Inter-Department Charges (IDC)  
Inter-Department Services (IDS)

I. REQUEST IS HEREBY submitted to the Auditor-Controller to prepare Journal Entry:

DEPARTMENT TO BE REIMBURSED Kelseyville Fire 9553 for work performed.  
(Budget Title) (Budget No.)

Description #1: SBCA Grant portion distribution Project #: \_\_\_\_\_

Description #2: FEMA -AFG grant

Approved by: \_\_\_\_\_ (Date)  
(Receiving/Authorized Signature)

II. DEPARTMENT TO BE CHARGED: Northshore Fire 9555 for work performed.  
(Budget Title) (Budget No.)

Description #1: SBCA Grant portion distribution Project #: \_\_\_\_\_

Description #2: FEMA -AFG grant

Approved by: *C Jimenez* *12/11/2009*  
(Authorized Signature) (Date)

III. Detail prepared by Department requesting Reimbursement.  
Detail verified by Department to be charged.

	FUND 000	DEPT 0000	ACCOUNT 000.00-00	DEBIT	CREDIT
I.	355	9555	453.56-30	127,439.03	
II.	353	9553	453.56-30		127,439.03

IV. Auditor Controller only:

Review of Sections I, II, & III is determined to be complete, documented and approved by authorized signatures.

Journal Entry Number: \_\_\_\_\_ Date: \_\_\_\_\_

Prepared by: \_\_\_\_\_  
(Deputy)

County of Lake  
Office of the Auditor-Controller  
Inter-Department Charges (IDC)  
Inter-Department Services (IDS)

I. REQUEST IS HEREBY submitted to the Auditor-Controller to prepare Journal Entry:  
DEPARTMENT TO BE REIMBURSED South Lake Fire 9557 for work performed.  
(Budget Title) (Budget No.)

Description #1: SBCA Grant portion distribution Project #: \_\_\_\_\_  
Description #2: FEMA -AFG grant

Approved by: \_\_\_\_\_ (Date)  
(Receiving/Authorized Signature)

II. DEPARTMENT TO BE CHARGED: Northshore Fire 9555 for work performed.  
(Budget Title) (Budget No.)

Description #1: SBCA Grant portion distribution Project #: \_\_\_\_\_  
Description #2: FEMA -AFG grant

Approved by:  12/1/2020  
(Authorized Signature) (Date)

III. Detail prepared by Department requesting Reimbursement.  
Detail verified by Department to be charged.

	FUND 000	DEPT 0000	ACCOUNT 000.00-00	DEBIT	CREDIT
I.	355	9555	453.56-30	193,928.96	
II.	357	9557	453.56-30		193,928.96

IV. **Auditor Controller only:**  
Review of Sections I, II, & III is determined to be complete, documented and approved by authorized signatures.

Journal Entry Number: \_\_\_\_\_ Date: \_\_\_\_\_

Prepared by: \_\_\_\_\_  
(Deputy)

SCBA's and Districts

"Exhibit C"



# INVOICE

**INVOICE NUMBER: 228081**  
**INVOICE DATE:** 15-Nov-20  
**DATE SHIPPED:** 13-Nov-20  
**PAYMENT TERMS:** NET 30

ALLSTAR FEDERAL TAX I.D. NUMBER: 95-4326274



**PURCHASE ORDER:** 2020-01

**SOLD TO:** Northshore FPD  
Attn: Accounts Payable  
P.O. Box 1199  
Lucerne, CA 95458

**SHIP TO:** Northshore FPD  
6257 7th Ave.  
Lucerne, CA 95458  
Attn: Mike Ciancio

**MARK FOR:** 2020-01

**SHIPPED VIA:** DROP SHIPPED

**CODE:** 50  
152063

QTY	UNIT	DESCRIPTION	UNIT PRICE	EXTENSION
160	EA	Complete SCBA System, per Cal Fire Requirements System Includes: (1) Scott X3 Pro Air-Pak, 4500 PSI with CGA Connection, QD Regulator, Dual UEBSS (Buddy Breathing) with RECTUS Connection, PASS with Pak-Tracker, with Standard Waist Belt (1) 45 Minute, Carbon Wrapped Cylinder with Valve, 4500 PSI Banded Identifier Included at No Charge (1) AV3000HT Facepiece with EPIC Voice Amp Bracket (1) EPIC Voice Amp	\$4,844.44	\$775,110.40
160	EA	Additional Carbon Wrapped Cylinder with Valve, 45 Minute, 4500 PSI, (5) for Additional Air-Paks	\$838.46	\$134,153.60

**Make all checks payable to:** ALLSTAR FIRE EQUIPMENT  
12328 Lower Azusa Road  
Arcadia, California 91006

SUBTOTAL	\$909,264.00
7.25% TAX	\$65,921.64
SHIPPING CHARGES	\$0.00

If you have any questions regarding this invoice, please call Customer Service at (626) 652-0900

**TOTAL \$975,185.64**

*Allstar Thanks You for Your Business !!!*

APPROVED BY: klf

# INVOICE



**INVOICE NUMBER: 228080**  
**INVOICE DATE: 15-Nov-20**  
**DATE SHIPPED: 13-Nov-20**  
**PAYMENT TERMS: NET 30**

ALLSTAR FEDERAL TAX I.D. NUMBER: 95-4326274

**PURCHASE ORDER:** PENDING



SOLD TO: South Lake County FPD  
**Attention: Accounts Payable**  
 PO Box 1360  
 Middletown, CA 95461

SHIP TO: Northshore FPD  
 6257 7th Ave.  
 Lucerne, CA 95458  
 Attn: Chief Ciancio

MARK FOR: PENDING

SHIPPED VIA: DROP SHIPPED

CODE: 50  
 152064

QTY	UNIT	DESCRIPTION	UNIT PRICE	EXTENSION
5	EA	Complete SCBA System, per Cal Fire Requirements System Includes: (1) Scott X3 Pro Air-Pak, 4500 PSI with CGA Connection, QD Regulator, Dual UEBSS (Buddy Breathing) with RECTUS Connection, PASS with Pak-Tracker, E-Z Escape Belt Pro, Fixed (1) 45 Minute, Carbon Wrapped Cylinder with Valve, 4500 PSI Banded Identifier Included at No Charge (1) AV3000HT Facepiece with EPIC Voice Amp Bracket (1) EPIC Voice Amp	\$5,097.14	\$25,485.70
35	EA	Update New Paks to Include E-Z Escape Rescue Belt	\$252.70	\$8,844.50
7	EA	Additional Carbon Wrapped Cylinder with Valve, 45 Minute, 4500 PSI, (5) for Additional Air-Paks	\$838.46	\$5,869.22
6	EA	Scott 201582-12 SIGHT Thermal Imager, Includes Scott AV3000HT Facepiece with Left Side Voice Amp Bracket Size: Medium	\$1,512.45	\$9,074.70
1	EA	Scott 201275-01 EPIC Voice Amp	\$403.19	\$403.19
2	EA	Scott 200954-02 RIT III 4500 PSI (Cylinder not Included) Can Use your Standard Issue 45 Minute Cylinder Will Accept Up to 60 Minute 4500 PSIG Includes: EZ Flo Regulator with 5' RIC Hose & RIT Facepiece, 6' EBSS Hose, Monitoring Console and Carry Bag	\$2,748.73	\$5,497.46

**"Exhibit C"**

QTY	UNIT	DESCRIPTION	UNIT PRICE	EXTENSION
<b>Make all checks payable to:</b> ALLSTAR FIRE EQUIPMENT 12328 Lower Azusa Road Arcadia, California 91006			SUBTOTAL 7.25% TAX SHIPPING CHARGES	\$55,174.77 \$4,000.17 \$0.00
If you have any questions regarding this invoice, please call Customer Service at (626) 652-0900			<b>TOTAL</b>	<b>\$59,174.94</b>

*Allstar Thanks You for Your Business !!!*

APPROVED BY: kl7

## System for Award Management (SAM.gov) profile

Please identify your organization to be associated with this application.

All organization information in this section will come from the System for Award Management (SAM) profile for that organization.

### NORTHSHORE FIRE PROTECTION DISTRICT

Information current from SAM.gov as of:	<b>12/06/2020</b>
DUNS (includes DUNS+4):	<b>786142240</b>
Employer Identification Number (EIN):	<b>141983377</b>
Organization legal name:	<b>NORTHSHORE FIRE PROTECTION DISTRICT</b>
Organization (doing business as) name:	
Mailing address:	<b>6257 7TH AVE P.O. BOX 1199 LUCERNE, CA 95458-1199</b>
Physical address:	<b>6257 7TH AVE LUCERNE, CA 95458-0000</b>
Is your organization delinquent on any federal debt?	<b>N</b>
SAM.gov registration status:	<b>Active as of 02/12/2020</b>
<input checked="" type="checkbox"/> We have reviewed our bank account information on our SAM.gov profile to ensure it is up to date	

## Applicant information

Please provide the following additional information about the department or organization applying for this grant.

Applicant name (i.e., fire department name)	<b>Mike Ciancio</b>
---	---------------------

## Main address of location impacted by this grant

Main address 1	<b>6257 7th Ave</b>
Main address 2	<b>PO Box 1199</b>
City	<b>Lucerne</b>
State/territory	<b>CA</b>
Zip code	<b>95458</b>



Zip extension

1199

In what county/parish is your organization physically located? If you have more than one station, in what county/parish is your main station located?

Northshore Fire Protection District

## Applicant characteristics

The Assistance to Firefighters Grants Program's objective is to provide funding directly to fire departments and nonaffiliated EMS organizations or a State Fire Training Academy for the purpose of protecting the health and safety of the public and first responder personnel against fire and fire-related hazards. Please review the Notice of Funding Opportunity Announcement (NOFO) for information on available program areas and for more information on the evaluation process and conditions of award.

Please provide the following additional information about the applicant.

Applicant type:

Fire Department/Fire District

Is this grant application a regional request? A regional request provides a direct regional and/or local benefit beyond your organization. You may apply for a regional request on behalf of your organization and any number of other participating eligible organizations within your region.

Yes

What kind of organization do you represent?

Combination (Majority Paid/Career)

What is the percentage of career members in your organization?

85

Please explain how this request benefits other organizations.

**This request will allow the region partners to better assist each other in mutual aid responses. It will allow a standardization and familiarity of equipment across all departments, because of the standardization and familiarity of the equipment will provide for better fire ground safety.**

Per the Notice of Funding Opportunity, do you have a Memorandum of Understanding (MOU) or equivalent document in place?

No

How many regional partners will directly participate in this project?

6

Please list each participating agency by name along with a point of contact (POC), to include a phone number. All regional participants must be eligible as defined by the Notice of Funding Opportunity.

Participating organization name	POC first name	POC last name	Phone number	Phone number extension	EIN
Northshore Fire	Mike	Ciancio	7072743100		*****
Lake Co. Fire	Willie	Sapeta	7079942170		*****
Lakeport Fire	Rick	Bergem	7072634397		*****
South Lake Co. Fire	Mike	Wink	7079631599		*****
Kelseyville Fire	Joe	Huggins	7072794268		*****
Lake Pillsbury Fire	Larry	Thompson	7077341884		*****

How many active firefighters does your region have who perform firefighting duties? This is the combined personnel of all departments/agencies included in this application. **130**

How many of the active firefighters in your region are trained to the level of Firefighter I or equivalent? **124**

How many of the active firefighters in your region are trained to the level of Firefighter II or equivalent? **61**

Are you requesting training funds in this application to bring 100% of the firefighters in your region into compliance with NFPA 1001? **No**

How many members in your region are trained to the level of EMR or EMT, Advanced EMT or Paramedic? **96**

Do the departments in your region have a Community Paramedic program? **No**

Do the departments in your region have a Community Paramedic program? **No**

How many stations are in your region? **16**

Does your region protect critical infrastructure of the state? **Yes**

Please describe the critical infrastructure protected below. **The region protects a Cal Pine Thermo-geo electrical plant, the Trans Continental Fiber Optic Line and a State Hwy that connects the Sacramento Valley with Northern Ca. coastal communities. It is one of two highways that allow for commerce to be transported from inland**

**California to most of cities north of San Francisco.**

Do all departments in this request report to NFIRS? **Yes**

Please enter the FDIN/FDID of the host department. **17055**

## Operating budget

What is your organizations operating budget (e.g., personnel, maintenance of apparatus, equipment, facilities, utility costs, purchasing expendable items, etc.) dedicated to expenditures for day-to-day activities for the current (at time of application) fiscal year, as well as the previous two fiscal years?

Current fiscal year: **2019**

Fiscal Year	Operating budget
2019	\$20,012,829.00
2018	\$18,684,830.00
2017	\$18,427,580.00

What percentage of the declared operating budget is **59** dedicated to personnel costs (salary, benefits, overtime costs, etc.)?

What percentage of the declared operating budget is derived from the following	2019	2018	2017
Taxes	35	41	37
Bond issues	0	0	0
EMS billing	32	35	37
Grants	0	0	0
Donations	0	0	0
Fund drives	0	0	0

**What percentage of the declared operating budget is derived from the following**

	<b>2019</b>	<b>2018</b>	<b>2017</b>
Fee for service	30	21	21
Other	3	3	5
<b>Totals</b>	100 %	100 %	100 %

Please explain the "Other" portion of the declared operating budget.

**All regional partners collect "other" revenues from business inspections, MOU agreements with Tribal Nations to provide Fire Protection & mitigation fees from new construction.**

Describe your financial need and how consistent it is with the intent of the AFG Program. Include details describing your organization's financial distress such as summarizing budget constraints, unsuccessful attempts to secure other funding, and proving the financial distress is out of your control.

**Revenues received from property taxes are the most significant revenue source for the regional partners. Lake County real estate markets were hit very hard during the recession. While this trend appears to be waning, assessed property values have been slow to recover. Many property owners have chosen to not rebuild due to the threat of devastating fires. As an example, the Valley Fire of 2015 which destroyed 1955 structures, & to date only 400 structures have been rebuilt. The fires after 2015 including the Clayton Fire, Sulphur Fire and the 2018 Mendocino Complex fire which was made up of both the River and Ranch Fires have only made the situation more difficult. Over 64% of the county land mass has been burned in the last 6 years. Lake County is among the lowest in the state from economic stand point and the last 6 years of devastating fires have crippled Lake county from rebounding. At the same time, emergency call volume has increased in the region more than 30% since 2010 and is expected to continue rising, placing added strain on fixed or fewer resources. Compounding the funding shortfall, the increasing costs of healthcare, worker's compensation insurance, and long-term retirement obligations over the same time period have placed additional demands on the regional partners budgets. Labor costs continue to increase and as a result of these factors, the applicants have shifted funding priorities from equipment, supplies, and programs to personnel in an effort to maintain service levels, forgoing the purchase of equipment and supplies that**

**"Exhibit D"**

**cannot be deferred indefinitely. Funding shortfalls have left open positions in many of the partner agencies vacant or even eliminated in some cases. Funding is simply insufficient for replacement of large capital items such as SCBA. The replacement of SCBA's for 3 of the agencies is a priority due to the fact the vendor supporting their SCBA's is no longer in business in the United States. Similar funding impacts for all regional partners have resulted in the inability to fund much-needed safety equipment. Responding to funding shortfalls, several partner agencies have attempted unsuccessfully to secure additional funding through voter approved measures. Northshore Fire Protection District (NFPD) has attempted to pass local tax measures without success. NFPD has done constituent surveys that came back unfavorable for passage of any measure to increase fire fees or taxes anytime in the foreseeable future. Lake County Fire Protection District passed a special tax in 2014. In spring 2019, Lake County Fire projected it may need to go back out to voters due to the loss of revenue from three devastating fires that came through their fire district. As further evidence of the funding challenges faced by the applicants, many applicants are supplementing current operating budgets with reserve monies acquired in prior years. Funding constraints have resulted in continued deferrals of necessary capital and other large-scale expenditures (including facilities maintenance, apparatus replacement, and training resources). Use of reserves to balance the budget is a practice that isn't sustainable in the long term. Without grant funding, the purchase of requested equipment will be further delayed.**

In cases of demonstrated economic hardship, and upon the request of the grant applicant, the FEMA Administrator may grant an Economic Hardship Waiver. Is it your organization's intent to apply for an Economic Hardship Waiver?

**Yes**

Which type of waiver will you be applying for?

Cost share

**Yes**

Maintenance of effort

**No**

## Community description

Please provide the following additional information about the community your organization serves.

Type of jurisdiction served **County**

What type of community does your organization serve? **Rural**

What is the square mileage of your first due response zone/jurisdiction served? **1330**

<b>What percentage of your primary response area is for the following:</b>	<b>Percentage (must sum to 100%)</b>
Agriculture, wildland, open space, or undeveloped properties	93
Commercial and industrial purposes	1
Residential purposes	6
<b>Total</b>	<b>100</b>

What is the permanent resident population of your first due response zone/jurisdiction served? **64355**

Do you have a seasonal increase in population? **Yes**

What is your seasonal increase in population? **10000**

Please describe your organization and/or community that you serve. **Together the 6 fire departments staff 12 stations, all of the partner agencies serve (Lake County) and is very diverse in landscape. The region is especially unique not only due to the geographic diversity, but also because of heightened risk factors including a large wildland-urban interface area (93%), high percentage of population living in poverty (42%), and a large population of children and elderly (41%) which is expected to grow. The county includes two incorporated cities, the Mendocino National Forest, the Boggs Mountain State Forest, Lake Pillsbury and Clear Lake, one of the largest natural lakes in the nation. The regional partners protect critical infrastructure that include, the Trans- continental fiber transmission line, electrical energy plant, utility distribution hubs (transmitters,**

**transformers, pumping stations), and water impoundments for public drinking water. We also have a main State Highway 20 that connects the Sacramento Valley with communities on the norths Coast. This State highway is the main transportation route for commerce from the Sacramento valley to communities on the Norths Coast. All of the partner agencies provide automatic aid within the Lake County Operational area and to surrounding counties that include Mendocino, Colusa and Napa. The region partners also participate in the State mutual aid response system which provides Type I and Type III engine companies and overhead upon request of the California Office of Emergency Services. Tactical emergency medical support is provided to the Lake County Sheriffs Office and both Municipal Police departments.**

## Applicant and community trends

**Please provide the following additional information about the applicant.**

<b>Injuries and fatalities</b>	<b>2019</b>	<b>2018</b>	<b>2017</b>
What is the total number of line of duty member fatalities in your region over the last three calendar years?	0	0	0
What is the total number of line of duty member injuries in your region over the last three calendar years?	11	8	9

How many vehicles does your organization have in each of the type or class of vehicle listed below? You must include vehicles that are leased or on long-term loan as well as any vehicles that have been ordered or otherwise currently under contract for purchase or lease by your organization but not yet in your possession.



### **Seated riding positions**

The number of seated riding positions must be equal or greater than the total number of frontline and reserve apparatus. If there are zero frontline and zero reserve apparatus, the number of seated riding positions must be zero..

<b>Type or class of vehicles</b>	<b>Number of frontline apparatus</b>	<b>Number of reserve apparatus</b>	<b>Number of seated riding positions</b>
----------------------------------	--------------------------------------	------------------------------------	--

**"Exhibit D"**

Type or class of vehicles	Number of frontline apparatus	Number of reserve apparatus	Number of seated riding positions
Engines or pumpers (pumping capacity of 750 gallons per minute (GPM) or greater and water capacity of 300 gallons or more): pumper, pumper/tanker, rescue/pumper, foam pumper, CAFS pumper, type I, type II engine urban interface.	18	5	70
Ambulances for transport and/or emergency response.	19	6	50
Tankers or tenders (water capacity of 1,000 gallons or more).	7	0	14
Aerial apparatus: aerial ladder truck, telescoping, articulating, ladder towers, platform, tiller ladder truck, quint.	2	0	12
Brush/quick attack (pumping capacity of less than 750 GPM and water carrying capacity of at least 300 gallons): brush truck, patrol unit (pickup w/ skid unit), quick attack unit, mini-pumper, type III engine, type IV engine, type V engine, type VI engine, type VII engine.	14	6	51
Rescue vehicles: rescue squad, rescue (light, medium, heavy), technical rescue vehicle, hazardous materials unit.	8	1	19
Additional vehicles: EMS chase vehicle, air/light unit, rehab units, bomb unit, technical support (command, operational support/supply), hose tender, salvage truck, ARFF (aircraft rescue firefighting), command/mobile communications vehicle.	20	0	61

Are the organizations in your region facing a new risk, **Yes** expanding service to a new area, or experiencing an increased call volume?

Please describe the critical infrastructure protected below.

**Fire Department/Fire District**

Please explain how your department is facing a new risk, expanding service to a new area, or experiencing an increased call volume.

**Lake County continues to see a rise in call volume each year which is out pacing the resources available. All of the regional partners continue to work on ways to lessen the impact for all. One way has been to drop borders and respond the closest resource. This has help with a faster response to some unincorporated areas of the county and has shown the need to have more continuity and inoperability among region partners.**



## Call volume

<b>Summary</b>	<b>2019</b>	<b>2018</b>	<b>2017</b>
Fire - NFIRS Series 100	550	575	514
Overpressure Rupture, Explosion, Overheat (No Fire) - NFIRS Series 200	6	2	8
Rescue & Emergency Medical Service Incident - NFIRS Series 300	9958	8881	8881
Hazardous Condition (No Fire) - NFIRS Series 400	410	205	209
Service Call - NFIRS Series 500	1167	1373	1547
Good Intent Call - NFIRS Series 600	1715	1429	776
False Alarm & Falls Call - NFIRS Series 700	312	310	242
Severe Weather & Natural Disaster - NFIRS Series 800	23	39	34
Special Incident Type - NFIRS Series 900	32	17	16
<b>Fires</b>	<b>2019</b>	<b>2018</b>	<b>2017</b>
"Structure Fire" (Of the NFIRS Series 100 calls, NFIRS Codes 111-120)	196	220	138
"Vehicle Fire" (Of the NFIRS Series 100 calls, NFIRS Codes 130-138)	173	135	104
"Vegetation Fire" (Of the NFIRS Series 100 calls, NFIRS Codes 140-143)	134	209	226
Total acreage of all vegetation fires	1041	547287	6202
<b>Rescue and Emergency Medical Service Incidents</b>	<b>2019</b>	<b>2018</b>	<b>2017</b>
"Motor Vehicle Accidents" (Of the NFIRS Series 300 calls, NFIRS Codes 322-324)	564	597	487
"Extractions from Vehicles" (Of the NFIRS Series 300 calls, NFIRS Code 352)	15	11	6
"Rescues" (Of the NFIRS Series 300 calls, NFIRS Code 300, 351, 353-381)	105	193	384
EMS-BLS Response Calls	3775	4181	3894
EMS-ALS Response Calls	4702	5447	4913
EMS-ALS Scheduled Transports	1128	1215	1400
Community Paramedic Response Calls	0	0	0

**Mutual and Automatic Aid**

	2019	2018	2017
Amount of times the organization received Mutual Aid	544	329	387
Amount of times the organization received Automatic Aid	830	623	607
Amount of times the organization provided Mutual Aid	439	218	194
Amount of times the organization provided Automatic Aid	360	226	196
Of the Mutual and Automatic Aid responses, amount that were structure fires	83	82	78

# Grant request details Grand total: \$975,185.64

## Program area: Operations and safety

### Total requested for Personal Protective Equipment (PPE) activity: \$975,185.64

**SCBA: SCBA Unit includes: Harness/Backpack, Face Piece and 2 cylinders**

QUANTITY	UNIT PRICE	TOTAL	BUDGET CLASS
160	\$5,682.90	\$909,264.00	Personnel

**DESCRIPTION**

System includes: (1) Scott X3 PRO Air-pak. 4500psi with CGA Connection QD Regulator with Rectus Connector, Dual UEBSS (Buddy Breathing) , PASS w/Pak-tracker, With Standard Waist Belt. (1) 45 minute, Carbon Wrapped Cylinder with Valve, 4500psiBanded Identifier included @ No Charge. (1) AV3000 HT Facepiece with Epic Voice Amp Bracket. (1) Epic Voice Amp Additional Carbon Wrapped Cylinder with Valve, 45 minute, 4500 psi.

**More Details for SCBA: SCBA Unit includes: Harness/Backpack, Face Piece and 2 cylinders.**

What is the purpose of this request? **Replace unusable/unreparable equipment to meet current standard**

Is your department trained in the proper use of **Yes**

the PPE/SCBA being requested?

Are you requesting funding for training for this PPE/SCBA? **No**

If you are not requesting training funds through this application, will you obtain training for this PPE/SCBA through other sources? **Yes**

How many of your seated riding positions currently have compliant SCBA assigned to it? **None**

**To which edition(s) of the NFPA 1981 standard are your SCBA or Cylinders compliant? Please account for all SCBA/Cylinders currently in your department's inventory, not just the SCBA/Cylinders you wish to replace. If you have damaged or inoperable items, please list them in the "Obsolete/non-compliant" section.**

Year	SCBA Current Inventory	SCBA Being Replaced	Cylinders Current Inventory	Cylinders Being Replaced
2018 Edition	0	0	0	0
2013 Edition	0	0	0	0
2007 Edition and older	97	97	97	97
Obsolete/non-compliant	63	63	63	63

**Additional funding**

QUANTITY	UNIT PRICE	TOTAL	BUDGET CLASS
1	\$65,921.64	\$65,921.64	Other

**DESCRIPTION**

Additional Funding is the Sales Tax of 7.25% for the purpose of SCBA units.

**More Details for Additional funding.**

What is the purpose of this request? **Replace unusable/unreparable equipment to meet current standard**

Is your department trained in the proper use of the PPE/SCBA being requested? **Yes**

Are you requesting funding for training for this PPE/SCBA? **No**

If you are not requesting training funds through this application, will you obtain training for this PPE/SCBA through other sources? **Yes**

## More Details for Personal Protective Equipment (PPE).

### Narrative

#### Project Description

**The Northshore Fire Protection District(NFPD), on behalf of its regional partners including Lake County Fire Protection District(LCFPD), South Lake County Fire Protection District(SLCFD), Kelseyville Fire District( KFD), Lakeport Fire Protection District(LFPD), and Lake Pillsbury Fire Department(LPFD), requests funding for 160 SCBA units and 49 additional face pieces to replace obsolete equipment that is beyond its serviceable life. The age and condition of existing SCBA, combined with high utilization, make this project an absolute and immediate necessity to ensure firefighter safety. Existing SCBA are between 10-19 years old with over 75% being 13+ years old and 51 units deemed by the vendor as not serviceable. Problems with existing SCBA include broken pack frames, fraying harnesses, failing HUD's, battery replacement issues, cracked hoses, and leaking MMR's. Existing SCBA are also not CBRNE certified and do not fully protect our members against known hazards. These types of issues necessitate continuous repairs and result in units being taken out of service. In addition to these problems, existing SCBA are not compliant with current NFPA 1981 standards and lack critical safety features such as 33% low air alarms and universal RIC attachments. The problems that our members deal with on a day to day basis with existing SCBA cause delays, inefficiencies, and, most importantly, compromise firefighter safety.**

**"Exhibit D"**

**Based on the number of seated riding positions for each partner agency, the distribution of SCBA units to each agency will be as follows: NFPD - 33 SCBA LCFPD - 27 SCBA SLCFD - 35 SCBA KFD - 23 SCBA LFPD - 29 SCBA LFD - 13 SCBA**

**The project budget is broken down as follows: 160 SCBA units @ \$5682.90/unit = \$909264.00 Local sales tax @ 7.25% = 65921.64 Project Total = \$975185.64 Federal Share = \$975185.64 Applicant Share = Request Wavier**

**The request for 160 units accounts for 100% of the seated riding positions for front line IDLH response apparatus for all partner agencies. The South Lake County Fire District has a schedule "A" contract with Cal Fire to provide fire protection. The regional partners have all agreed to partner with our State Agency (Cal Fire) and piggy back onto their bid process so that all agencies within the Lake County Operational area is wearing a compatible SCBA. This allows for better interoperability on auto/mutual aid responses. The region has one mobile air unit available to them, with all regional partners having the same SCBA the mobile air unit will be able to meet all partners needs to refill SCBA's. Although the applicant is asking for a economic hardship waiver if awarded the grant and denied the waiver, all regional partners have agreed this project is a life safety priority and are committed to providing the applicant share of \$97,518.64 funding necessary to complete the project in its entirety all at once in order to ensure firefighter safety and maximize cost savings through a large quantity purchase. Letters of Commitment from all partner agencies are currently in place. Training and familiarization with the new SCBA will be conducted in-house, therefore no additional funds are required for training. The regional partners have worked together to develop a specification for the project, and are prepared to complete the project within the 1-year performance period. The regional SCBA replacement project supports the AFG Program's purpose of enhancing firefighter safety and is considered a high priority project under AFG's SCBA Priorities as 100% of the regional partners' front line SCBA are more than 10 years old and are NFPA 1981 2002 Edition.. Funding this project will ensure the regional partners' SCBA units are 100% NFPA**

**compliant, ensuring our firefighters are protected at the highest level.**

Cost/Benefit

**One of the most basic necessities for firefighting is adequate protection for firefighters. Without this protection, they are unable to perform their duty to preserve life and property. The most obvious and important benefit provided by this project will be enhanced safety and reduced risk for our members. Our members are our most valuable asset as demonstrated by the large percentage of our budgets dedicated to them. The fact that cuts in our budgets are made to virtually all other types of expenses before our personnel costs is a testament to the value we place on our members. Our members are critical to our collective missions. Without them, we would not be able to serve our communities. With this in mind, the commitment to safeguard their safety cannot be overstated. SCBA units are a main component of personal protective equipment. The primary benefit of proper functioning SCBA is to ensure firefighters can safely enter IDLH environments and perform suppression and SAR activities. This single benefit leads to a chain reaction of benefits including increased effectiveness and efficiency of suppression and SAR activities, drop in property damage, and reduction of injuries and fatalities for firefighters and civilians. Interoperability is also a consideration due to high automatic aid rates between regional partners. Proper functioning of this equipment is a matter of life and death. It is clear that the benefits for funding this project far outweigh the cost. Increasingly high call volume and high SCBA utilization make certain that, if awarded, AFG Program funds will be well spent to maximize benefits. Value is further maximized through cost savings achieved with a large quantity purchase and piggy backing onto the Cal Fire Bid, overmatch from the regional partners, and enhanced interoperability in the region. The current financial constraints of the partner agencies prevent them from completing this critical project in its entirety in a timely manner without federal assistance. Existing SCBA units are already considered obsolete and are rapidly becoming totally inoperable. The partner**

**agencies simply can't afford to wait any longer to implement this project.**

## Statement of Effect

**The most basic shared mission of the regional partners is to protect life and property. This mission continues to be compromised by unreliable SCBA's. They are one of the most utilized pieces of PPE for our personnel and one of the most vital for firefighter safety. Daily operations continue to be negatively impacted by the age and condition of our SCBA's. Leaks and reduced air capacity cause delays and interruptions in suppression and SAR operations as members are forced to monitor bottles and swap them out more frequently. Problems with voice amplification compromises communication in critical situations. Ongoing issues with HUD reduce firefighter safety as members can't be 100% sure how much air is left in their bottles. Lack of CBRNE certification exposes our members to known risks. The increasing burden of maintaining this equipment results in more units being out of service and weakens operational continuity. All of these concerns diminish firefighter confidence and add unnecessary stress in an already highly stressful environment. The psychological impact of unreliable equipment leads to inefficient firefighter operations and heightened risk of injury and death. If awarded, the replacement of SCBA's will substantially improve firefighting operations. An SCBA unit will be designated to every seated riding position for apparatus responding to IDLH incidents and will be 100% compliant with the most current NFPA safety standards. Better ergonomic design will reduce firefighter fatigue and injury. CBRNE certification will ensure our members are protected at the highest level against known respiratory risks. Enhanced HUD and low air alarms will improve control of air supply. Universal RIC attachments and enriched voice amplification will expand interoperability in a high auto-aid region. In addition to the operational benefits that this project will realize, the partner agencies will no longer carry the existing maintenance burden that currently eats up precious funding in our budgets. If awarded, cost savings from maintenance and repairs could be allocated to**

**other deferred maintenance and equipment purchases, resulting in further benefits to the partner agencies. Overall, the daily benefits of the SCBA replacement program result in more effective operations and better incident outcomes. This project advances the regional partners' capability to fulfill their critical mission of preserving life and property and fulfills the AFG Program's purpose of enhancing the safety of the public and of firefighters.**

## Grant request summary

The table below summarizes the number of items and total cost within each activity you have requested funding for. This table will update as you change the items within your grant request details.

### Grant request summary

Activity	Number of items	Total cost
Personal Protective Equipment (PPE)	2	\$975,185.64
<b>Total</b>	<b>2</b>	<b>\$975,185.64</b>

Is your proposed project limited to one or more of the following activities ⓘ : Planning and development of policies or processes. Management, administrative, or personnel actions. Classroom-based training. Acquisition of mobile and portable equipment (not involving installation) on or in a building.

Yes

## Budget summary

### Budget summary

Object class categories	Total
Personnel	\$909,264.00
Fringe benefits	\$0.00



<b>Object class categories</b>	<b>Total</b>
Travel	\$0.00
Equipment	\$0.00
Supplies	\$0.00
Contractual	\$0.00
Construction	\$0.00
Other	\$65,921.64
<b>Total direct charges</b>	<b>\$975,185.64</b>
Indirect charges	\$0.00
<b>TOTAL</b>	<b>\$975,185.64</b>
<b>Non-federal resources</b>	
Applicant	\$
State	\$0.00
Other sources	\$88,653.24
Remarks	
<b>Total Federal and Non-federal resources</b>	
Federal resources	\$886,532.40
Non-federal resources	\$88,653.24
<b>TOTAL</b>	<b>\$975,185.64</b>
Program income	\$0.00

## Contact information

No

**Secondary point of contact**

---

Please provide a secondary point of contact for this grant.

The Authorized Organization Representative (AOR) who submits the application will be identified as the primary point of contact for the grant. Please provide one secondary point of contact for this grant below. The secondary contact can be members of the fire department or organizations applying for the grant that will see the grant through completion, are familiar with the grant application, and have the authority to make decisions on and to act upon this grant application. The secondary point of contact can also be an individual who assisted with the development, preparation, or review of the application.

**Willie Sapeta**

Fire Chief

**Primary phone**

7079942170

Work

**Additional phones**

7074890966

Mobile

**Fax**

[fdchf700@yahoo.com](mailto:fdchf700@yahoo.com)

## Assurance and certifications

OMB number: 4040-0007, Expiration date: 02/28/2022 [View burden statement](#)

### SF-424B: Assurances - Non-Construction Programs

OMB Number: 4040-0007

Expiration Date: 02/28/2022

Certain of these assurances may not be applicable to your project or program. If you have any questions, please contact the awarding agency. Further, certain Federal awarding agencies may require applicants to certify to additional assurances. If such is the case, you will be notified.

As the duly authorized representative of the applicant, I certify that the applicant:

1. Has the legal authority to apply for Federal assistance and the institutional, managerial and financial capability (including funds sufficient to pay the non-Federal share of project cost) to ensure proper planning, management and completion of the project described in this application.
2. Will give the awarding agency, the Comptroller General of the United States and, if appropriate, the State, through any authorized representative, access to and the right to examine all records, books, papers, or documents related to the award; and will establish a proper accounting system in accordance with generally accepted accounting standards or agency directives.
3. Will establish safeguards to prohibit employees from using their positions for a purpose that constitutes or presents the appearance of personal or organizational conflict of interest, or personal gain.
4. Will initiate and complete the work within the applicable time frame after receipt of approval of the awarding agency.

5. Will comply with the Intergovernmental Personnel Act of 1970 (42 U.S.C. §§4728-4763) relating to prescribed standards for merit systems for programs funded under one of the 19 statutes or regulations specified in Appendix A of OPM's Standards for a Merit System of Personnel Administration (5 C.F.R. 900, Subpart F).
6. Will comply with all Federal statutes relating to nondiscrimination. These include but are not limited to: (a) Title VI of the Civil Rights Act of 1964 (P.L. 88-352) which prohibits discrimination on the basis of race, color or national origin; (b) Title IX of the Education Amendments of 1972, as amended (20 U.S.C. §§1681-1683, and 1685-1686), which prohibits discrimination on the basis of sex; (c) Section 504 of the Rehabilitation Act of 1973, as amended (29 U.S.C. §794), which prohibits discrimination on the basis of handicaps; (d) the Age Discrimination Act of 1975, as amended (42 U.S.C. §§6101-6107), which prohibits discrimination on the basis of age; (e) the Drug Abuse Office and Treatment Act of 1972 (P.L. 92-255), as amended, relating to nondiscrimination on the basis of drug abuse; (f) the Comprehensive Alcohol Abuse and Alcoholism Prevention, Treatment and Rehabilitation Act of 1970 (P.L. 91-616), as amended, relating to nondiscrimination on the basis of alcohol abuse or alcoholism; (g) §§523 and 527 of the Public Health Service Act of 1912 (42 U.S.C. §§290 dd-3 and 290 ee- 3), as amended, relating to confidentiality of alcohol and drug abuse patient records; (h) Title VIII of the Civil Rights Act of 1968 (42 U.S.C. §§3601 et seq.), as amended, relating to nondiscrimination in the sale, rental or financing of housing; any other nondiscrimination provisions in the specific statute(s) under which application for Federal assistance is being made; and, (j) the requirements of any other nondiscrimination statute(s) which may apply to the application.
7. Will comply, or has already complied, with the requirements of Titles II and III of the Uniform Relocation Assistance and Real Property Acquisition Policies Act of 1970 (P.L. 91-646) which provide for fair and equitable treatment of persons displaced or whose property is acquired as a result of Federal or federally-assisted programs. These requirements apply to all interests in real property acquired for project purposes regardless of Federal participation in purchases.
8. Will comply, as applicable, with provisions of the Hatch Act (5 U.S.C. §§1501-1508 and 7324-7328) which limit the political activities of employees whose principal employment activities are funded in whole or in part with Federal funds.
9. Will comply, as applicable, with the provisions of the Davis-Bacon Act (40 U.S.C. §§276a to 276a-7), the Copeland Act (40 U.S.C. §276c and 18 U.S.C. §874), and the Contract Work Hours and Safety Standards Act (40 U.S.C. §§327-333), regarding labor standards for federally-assisted construction subagreements.
10. Will comply, if applicable, with flood insurance purchase requirements of Section 102(a) of the Flood Disaster Protection Act of 1973 (P.L. 93-234) which requires recipients in a special flood hazard area to participate in the program and to purchase flood insurance if the total cost of insurable construction and acquisition is \$10,000 or more.
11. Will comply with environmental standards which may be prescribed pursuant to the following: (a) institution of environmental quality control measures under the National Environmental Policy Act of 1969 (P.L. 91-190) and Executive Order (EO) 11514; (b) notification of violating facilities pursuant to EO 11738; (c) protection of wetlands pursuant to EO 11990; (d) evaluation of flood hazards in floodplains in accordance with EO 11988; (e) assurance of project consistency with the approved State management program developed under the Coastal Zone Management Act of 1972 (16 U.S.C. §§1451 et seq.); (f) conformity of Federal actions to State (Clean Air) Implementation Plans under Section 176(c) of the Clean Air Act of 1955, as amended (42 U.S.C. §§7401 et seq.); (g) protection of underground sources of drinking water under the Safe Drinking Water Act of 1974, as amended (P.L. 93-523); and, (h) protection of endangered species under the Endangered Species Act of 1973, as amended (P.L. 93-205).
12. Will comply with the Wild and Scenic Rivers Act of 1968 (16 U.S.C. §§1271 et seq.) related to protecting components or potential components of the national wild and scenic rivers system.

13. Will assist the awarding agency in assuring compliance with Section 106 of the National Historic Preservation Act of 1966, as amended (16 U.S.C. §470), EO 11593 (identification and protection of historic properties), and the Archaeological and Historic Preservation Act of 1974 (16 U.S.C. §§469a-1 et seq.).
14. Will comply with P.L. 93-348 regarding the protection of human subjects involved in research, development, and related activities supported by this award of assistance.
15. Will comply with the Laboratory Animal Welfare Act of 1966 (P.L. 89-544, as amended, 7 U.S.C. §§2131 et seq.) pertaining to the care, handling, and treatment of warm blooded animals held for research, teaching, or other activities supported by this award of assistance.
16. Will comply with the Lead-Based Paint Poisoning Prevention Act (42 U.S.C. §§4801 et seq.) which prohibits the use of lead-based paint in construction or rehabilitation of residence structures.
17. Will cause to be performed the required financial and compliance audits in accordance with the Single Audit Act Amendments of 1996 and OMB Circular No. A-133, "Audits of States, Local Governments, and Non-Profit Organizations."
18. Will comply with all applicable requirements of all other Federal laws, executive orders, regulations, and policies governing this program.
19. Will comply with the requirements of Section 106(g) of the Trafficking Victims Protection Act (TVPA) of 2000, as amended (22 U.S.C. 7104) which prohibits grant award recipients or a sub-recipient from (1) Engaging in severe forms of trafficking in persons during the period of time that the award is in effect (2) Procuring a commercial sex act during the period of time that the award is in effect or (3) Using forced labor in the performance of the award or subawards under the award.

## **Certifications regarding lobbying**

OMB Number: 4040-0013

Expiration Date: 02/28/2022

Certification for Contracts, Grants, Loans, and Cooperative Agreements

The undersigned certifies, to the best of his or her knowledge and belief, that:

1. No Federal appropriated funds have been paid or will be paid, by or on behalf of the undersigned, to any person for influencing or attempting to influence an officer or employee of an agency, a Member of Congress, an officer or employee of Congress, or an employee of a Member of Congress in connection with the awarding of any Federal contract, the making of any Federal grant, the making of any Federal loan, the entering into of any cooperative agreement, and the extension, continuation, renewal, amendment, or modification of any Federal contract, grant, loan, or cooperative agreement.
2. If any funds other than Federal appropriated funds have been paid or will be paid to any person for influencing or attempting to influence an officer or employee of any agency, a Member of Congress, an officer or employee of Congress, or an employee of a Member of Congress in connection with this Federal contract, grant, loan, or cooperative agreement, the undersigned shall complete and submit Standard Form-LLL, "Disclosure of Lobbying Activities," in accordance with its instructions.
3. The undersigned shall require that the language of this certification be included in the award documents for all subawards at all tiers (including subcontracts, subgrants, and contracts under grants, loans, and cooperative agreements) and that all subrecipients shall certify and disclose accordingly. This certification is a material representation of fact upon which reliance was placed when this transaction was made or entered into. Submission of this certification is a prerequisite for making or entering into this transaction imposed by section 1352, title 31, U.S. Code. Any person

who fails to file the required certification shall be subject to a civil penalty of not less than \$10,000 and not more than \$100,000 for each such failure.

### Statement for Loan Guarantees and Loan Insurance

The undersigned states, to the best of his or her knowledge and belief, that:

If any funds have been paid or will be paid to any person for influencing or attempting to influence an officer or employee of any agency, a Member of Congress, an officer or employee of Congress, or an employee of a Member of Congress in connection with this commitment providing for the United States to insure or guarantee a loan, the undersigned shall complete and submit Standard Form-LLL, "Disclosure of Lobbying Activities," in accordance with its instructions. Submission of this statement is a prerequisite for making or entering into this transaction imposed by section 1352, title 31, U.S. Code. Any person who fails to file the required statement shall be subject to a civil penalty of not less than \$10,000 and not more than \$100,000 for each such failure.

OMB number: 4040-0013, Expiration date: 02/28/2022 [View burden statement](#)

## SF-LLL: Disclosure of Lobbying Activities

OMB Number: 4040-0013

Expiration Date: 02/28/2022

Complete only if the applicant is required to do so by 44 C.F.R. part 18. Generally disclosure is required when applying for a grant of more than \$100,000 and if any funds other than Federal appropriated funds have been paid or will be paid to any person for influencing or attempting to influence an officer or employee of any agency, a Member of Congress, an officer or employee of Congress, or an employee of a Member of Congress in connection with this Federal contract, grant, loan, or cooperative agreement, the undersigned shall complete and submit Standard Form-LLL, "Disclosure Form to Report Lobbying," in accordance with its instructions. Further, the recipient shall file a disclosure form at the end of each calendar quarter in which there occurs any event described in 44 C.F.R. § 18.110(c) that requires disclosure or that materially affects the accuracy of the information contained in any disclosure form previously filed by the applicant.

The applicant is not currently required to submit the SF-LLL.

## Notice of funding opportunity

I certify that the applicant organization has consulted the appropriate Notice of Funding Opportunity and that all requested activities are programmatically allowable, technically feasible, and can be completed within the award's Period of Performance (POP).

## Accuracy of application

I certify that I represent the organization applying for this grant and have reviewed and confirmed the accuracy of all application information submitted. Regardless of intent, the submission of information that is false or misleading may result in actions by FEMA that include, but are not limited to: the submitted

application not being considered for award, enforcement actions taken against an existing award pending investigation or review, or referral to the DHS Office of Inspector General.

## **Authorized Organizational Representative for the grant**

By signing this application, I certify that I understand that inputting my password below signifies that I am the identified Authorized Organization Representative for this grant. Further, I understand that this electronic signature shall bind the organization as if the application were physically signed and filed.

## **Authorization to submit application on behalf of applicant organization**

By signing this application, I certify that I am either an employee or official of the applicant organization and am authorized to submit this application on behalf of my organization; or, if I am not an employee or official of the applicant organization, I certify that the applicant organization is aware I am submitting this application on its behalf, that I have written authorization from the applicant organization to submit this application on their behalf, and that I have provided contact information for an employee or official of the applicant organization in addition to my contact information.



**South Lake County Fire Protection District**  
— in cooperation with —  
**California Department of Forestry and Fire Protection**

---

P.O. Box 1360 Middletown, CA 95461 - (707) 987-3089

**DATE:** December 12, 2020  
**TO:** Board of Directors  
**FROM:** Gloria Fong  
Staff Services Analyst  
**SUBJECT:** Resolution No. 2020-21-12, A Resolution Pertaining to Tax Revenue Exchange for Jackson, Polanco and Rancheria Annex to Callayomi County Water District (CCWD) – Local Agency Formation Commission (LAFCO) Project #2020-001

Subject resolution is provided for Board’s consideration and approval. This resolution requests that property tax revenues generated shall not be changed as a result of the annexation.

Per Revenue and Taxation Code Section 99 (b) 3, the County Auditor-Controller has prepared the attached notifications of revenue estimate subject to negotiation and its exchange.

It has been my observation the County Board of Supervisors adopts a resolution similar to the attached and I’m offering the same.

Additional information about property tax revenue negotiation is contained in the attached Revenue and Taxation Code 99.

Attachments: 1) subject resolution  
2) County Auditor-Controller notification  
3) Revenue and Taxation Code Section 99

**BOARD OF DIRECTORS, SOUTH LAKE COUNTY FIRE PROTECTION DISTRICT**  
**COUNTY OF LAKE, STATE OF CALIFORNIA**

**RESOLUTION NO. 2020-21- 12**

**A RESOLUTION PERTAINING TO TAX REVENUE EXCHANGE  
FOR JACKSON, POLANCO AND RANCHERIA ANNEX  
TO CALLAYOMI COUNTY WATER DISTRICT (CCWD) –  
LOCAL AGENCY FORMATION COMMISSION (LAFCO) PROJECT #2020-001**

**WHEREAS**, Section 99 of the Revenue and Taxation Code requires, before the LAFCO Executive Officer issues a certification of filing for a proposed annexation, that an exchange of property tax revenue be negotiated between the affected agencies; and

**WHEREAS**, a proposed annexation has been filed with the LAFCO Executive Officer to certain properties to the CCWD, the LAFCO short form designation for such proposal is LAFCO Project #2020-001 – Jackson, Polanco, and Rancheria Annex to CCWD,

**NOW, THEREFORE, BE IT RESOLVED** that:

1. Upon finalization of the LAFCO Project #2020-001 – Jackson, Polanco, and Rancheria Annex to CCWD, property tax revenues generated from within annexation area shall be allocated as follows:

Base Property Tax: The base property tax revenue currently allocated to the South Lake Fire Protection District shall not be changed as a result of this annexation.

Future Property Tax Increment: The future property tax increment allocated to the South Lake County Fire Protection District shall not be changed as a result of this annexation.

2. The Clerk of the Board is directed to file a certified copy of this resolution with the Auditor-Controller's Office and LAFCO Executive Officer.

**THIS RESOLUTION** was introduced and adopted by the Board of Directors of the South Lake County Fire Protection District at a Regular Meeting on the 15<sup>th</sup> day of December, 2020 by the following vote:

AYES:

NOES:

ABSENT OR NOT VOTING:

SOUTH LAKE COUNTY  
FIRE PROTECTION DISTRICT

\_\_\_\_\_  
MADELYN MARTINELLI  
President, Board of Directors

ATTEST: \_\_\_\_\_  
Gloria Fong  
Clerk to the Board of Directors





**COUNTY OF LAKE**  
**Office of the Auditor-  
 Controller/County Clerk**  
**Courthouse-255 North Forbes Street**  
 Lakeport, CA 95453  
 Telephone (707) 263-2311  
 FAX (707) 263-2310  
 Email: Auditor@lakecountyca.gov

**Cathy Saderlund**  
 Auditor-Controller/County Clerk  
**Marcy Harrison**  
 Chief Deputy Auditor-Controller

Ref. No. 21L-053

November 17, 2020

Property Tax Exchange Pursuant to R & T §99

Pursuant to Section 99 (b) (3) of the Revenue and Taxation Code, your service area will be altered by the below designated application. This office is hereby notifying you that the property tax revenue for the following property is subject to a negotiated exchange.

LAFCO Project #2020-001 Jackson, Polanco, and Rancheria Annex to CCWD

**Tax Rate Areas:** 062-008  
**Assessments:** 014-160-010, 014-160-050, 014-160-090, 014-160-100  
**Net Value:** 1,571,540

<b>Agencies:</b>	<b>Tax Subject to Negotiation</b>
General County	5,779
Road	379
Co. Library	232
Fish & Wildlife	19
Flood - General	168
Middletown Cemetery	153
Lake County Resource Cons	11
South Lake Co. Fire	1,416
Lake Co. Vector Control Dist.	354
Co. Office of Ed	515
Middletown Unified	4,942
Yuba College	1,312
Redbud Healthcare District	435

Pursuant to Section 99 (b) (4) & (6) you have 60 days to negotiate an exchange of property tax revenue. Before the end of such 60 day period the County shall present a resolution summarizing our agreements to the Executive Officer of LAFCO.

Cathy Saderlund  
 Auditor-Controller

*Amanda Johnson*

By: Amanda Johnson  
 Property Tax Coordinator  
 cc:

John Benoit, LAFCO  
 Rich Ford, Assessor-Recorder  
 Carol Huchingson, County Administrative Officer

Middletown Cemetery  
 Department of Fish & Game

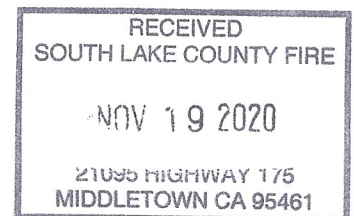

State Board of Equalization  
Department of Public Works  
Michelle Buell, County Office of Education  
Lake County Resource Conservation Dist.

Lake County Vector Control  
Yuba College  
Redbud Healthcare District  
South Lake County Fire

Attachment

## State of California

### REVENUE AND TAXATION CODE

#### Section 99

---

99. (a) For the purposes of the computations required by this chapter:

(1) In the case of a jurisdictional change, other than a city incorporation, city disincorporation, or a formation of a district as defined in Section 2215, the auditor shall adjust the allocation of property tax revenue determined pursuant to Section 96 or 96.1, or the annual tax increment determined pursuant to Section 96.5, for local agencies whose service area or service responsibility would be altered by the jurisdictional change, as determined pursuant to subdivision (b) or (c).

(2) In the case of a city incorporation or disincorporation, the auditor shall assign the allocation of property tax revenues determined pursuant to Section 56810 of the Government Code and the adjustments in tax revenues that may occur pursuant to Section 56815 of the Government Code to the newly formed city or district and shall make the adjustment as determined by Section 56810 or 56813 in the allocation of property tax revenue determined pursuant to Section 96 or 96.1 for each local agency whose service area or service responsibilities would be altered by the incorporation.

(3) In the case of a formation of a district as defined in Section 2215, the auditor shall assign the allocation of property tax revenues determined pursuant to Section 56810 of the Government Code to the district and shall make the adjustment as determined by Section 56810, or for the disincorporated city or dissolved district as determined by Section 56813, in the allocation of property tax revenue determined pursuant to Section 96 or 96.1 for each local agency whose service area or service responsibilities would be altered by the change of organization.

(b) Upon the filing of an application or a resolution pursuant to the Cortese-Knox-Hertzberg Local Government Reorganization Act of 2000 (Division 3 (commencing with Section 56000) of Title 5 of the Government Code), but prior to the issuance of a certificate of filing, the executive officer shall give notice of the filing to the assessor and auditor of each county within which the territory subject to the jurisdictional change is located. This notice shall specify each local agency whose service area or responsibility will be altered by the jurisdictional change.

(1) (A) The county assessor shall provide to the county auditor, within 30 days of the notice of filing, a report which identifies the assessed valuations for the territory subject to the jurisdictional change and the tax rate area or areas in which the territory exists.

(B) The auditor shall estimate the amount of property tax revenue generated within the territory that is the subject of the jurisdictional change during the current fiscal year.

(2) The auditor shall estimate what proportion of the property tax revenue determined pursuant to paragraph (1) is attributable to each local agency pursuant to Sections 96.1 and 96.5.

(3) Within 45 days of notice of the filing of an application or resolution, the auditor shall notify the governing body of each local agency whose service area or service responsibility will be altered by the jurisdictional change of the amount of, and allocation factors with respect to, property tax revenue estimated pursuant to paragraph (2) that is subject to a negotiated exchange.

(4) Upon receipt of the estimates pursuant to paragraph (3), the local agencies shall commence negotiations to determine the amount of property tax revenues to be exchanged between and among the local agencies. Except as otherwise provided, this negotiation period shall not exceed 60 days. If a local agency involved in these negotiations notifies the other local agencies, the county auditor, and the local agency formation commission in writing of its desire to extend the negotiating period, the negotiating period shall be 90 days.

The exchange may be limited to an exchange of property tax revenues from the annual tax increment generated in the area subject to the jurisdictional change and attributable to the local agencies whose service area or service responsibilities will be altered by the proposed jurisdictional change. The final exchange resolution shall specify how the annual tax increment shall be allocated in future years.

(5) In the event that a jurisdictional change would affect the service area or service responsibility of one or more special districts, the board of supervisors of the county or counties in which the districts are located shall, on behalf of the district or districts, negotiate any exchange of property tax revenues. Prior to entering into negotiation on behalf of a district for the exchange of property tax revenue, the board shall consult with the affected district. The consultation shall include, at a minimum, notification to each member and executive officer of the district board of the pending consultation and provision of adequate opportunity to comment on the negotiation.

(6) Notwithstanding any other provision of law, the executive officer shall not issue a certificate of filing pursuant to Section 56658 of the Government Code until the local agencies included in the property tax revenue exchange negotiation, within the negotiation period, present resolutions adopted by each such county and city whereby each county and city agrees to accept the exchange of property tax revenues.

(7) In the event that the commission modifies the proposal or its resolution of determination, any local agency whose service area or service responsibility would be altered by the proposed jurisdictional change may request, and the executive officer shall grant, 30 days for the affected agencies, pursuant to paragraph (4), to renegotiate an exchange of property tax revenues. Notwithstanding the time period specified in paragraph (4), if the resolutions required pursuant to paragraph (6) are not presented to the executive officer within the 30-day period, all proceedings of the jurisdictional change shall automatically be terminated.

(8) In the case of a jurisdictional change that consists of a city's qualified annexation of unincorporated territory, an exchange of property tax revenues between the city

and the county shall be determined in accordance with subdivision (e) if that exchange of revenues is not otherwise determined pursuant to either of the following:

(A) Negotiations completed within the applicable period or periods as prescribed by this subdivision.

(B) A master property tax exchange agreement among those local agencies, as described in subdivision (d).

For purposes of this paragraph, a qualified annexation of unincorporated territory means an annexation, as so described, for which an application or a resolution was filed on or after January 1, 1998, and on or before January 1, 2021.

(9) No later than the date on which the certificate of completion of the jurisdictional change is recorded with the county recorder, the executive officer shall notify the auditor or auditors of the exchange of property tax revenues and the auditor or auditors shall make the appropriate adjustments as provided in subdivision (a).

(c) Whenever a jurisdictional change is not required to be reviewed and approved by a local agency formation commission, the local agencies whose service area or service responsibilities would be altered by the proposed change, shall give notice to the State Board of Equalization and the assessor and auditor of each county within which the territory subject to the jurisdictional change is located. This notice shall specify each local agency whose service area or responsibility will be altered by the jurisdictional change and request the auditor and assessor to make the determinations required pursuant to paragraphs (1) and (2) of subdivision (b). Upon notification by the auditor of the amount of, and allocation factors with respect to, property tax subject to exchange, the local agencies, pursuant to the provisions of paragraphs (4) and (6) of subdivision (b), shall determine the amount of property tax revenues to be exchanged between and among the local agencies. Notwithstanding any other provision of law, no such jurisdictional change shall become effective until each county and city included in these negotiations agrees, by resolution, to accept the negotiated exchange of property tax revenues. The exchange may be limited to an exchange of property tax revenue from the annual tax increment generated in the area subject to the jurisdictional change and attributable to the local agencies whose service area or service responsibilities will be altered by the proposed jurisdictional change. The final exchange resolution shall specify how the annual tax increment shall be allocated in future years. Upon the adoption of the resolutions required pursuant to this section, the adopting agencies shall notify the auditor who shall make the appropriate adjustments as provided in subdivision (a). Adjustments in property tax allocations made as the result of a city or library district withdrawing from a county free library system pursuant to Section 19116 of the Education Code shall be made pursuant to Section 19116 of the Education Code, and this subdivision shall not apply.

(d) With respect to adjustments in the allocation of property taxes pursuant to this section, a county and any local agency or agencies within the county may develop and adopt a master property tax transfer agreement. The agreement may be revised from time to time by the parties subject to the agreement.

(e) (1) An exchange of property tax revenues that is required by paragraph (8) of subdivision (b) to be determined pursuant to this subdivision shall be determined in accordance with all of the following:

(A) The city and the county shall mutually select a third-party consultant to perform a comprehensive, independent fiscal analysis, funded in equal portions by the city and the county, that specifies estimates of all tax revenues that will be derived from the annexed territory and the costs of city and county services with respect to the annexed territory. The analysis shall be completed within a period not to exceed 30 days, and shall be based upon the general plan or adopted plans and policies of the annexing city and the intended uses for the annexed territory. If, upon the completion of the analysis period, no exchange of property tax revenues is agreed upon by the city and the county, subparagraph (B) shall apply.

(B) The city and the county shall mutually select a mediator, funded in equal portions by those agencies, to perform mediation for a period not to exceed 30 days. If, upon the completion of the mediation period, no exchange of property tax revenues is agreed upon by the city and the county, subparagraph (C) shall apply.

(C) The city and the county shall mutually select an arbitrator, funded in equal portions by those agencies, to conduct an advisory arbitration with the city and the county for a period not to exceed 30 days. At the conclusion of this arbitration period, the city and the county shall each present to the arbitrator its last and best offer with respect to the exchange of property tax revenues. The arbitrator shall select one of the offers and recommend that offer to the governing bodies of the city and the county. If the governing body of the city or the county rejects the recommended offer, it shall do so during a public hearing, and shall, at the conclusion of that hearing, make written findings of fact as to why the recommended offer was not accepted.

(2) Proceedings under this subdivision shall be concluded no more than 150 days after the auditor provides the notification pursuant to paragraph (3) of subdivision (b), unless one of the periods specified in this subdivision is extended by the mutual agreement of the city and the county. Notwithstanding any other provision of law, except for those conditions that are necessary to implement an exchange of property tax revenues determined pursuant to this subdivision, the local agency formation commission shall not impose any fiscal conditions upon a city's qualified annexation of unincorporated territory that is subject to this subdivision.

(f) Except as otherwise provided in subdivision (g), for the purpose of determining the amount of property tax to be allocated in the 1979–80 fiscal year and each fiscal year thereafter for those local agencies that were affected by a jurisdictional change which was filed with the State Board of Equalization after January 1, 1978, but on or before January 1, 1979. The local agencies shall determine by resolution the amount of property tax revenues to be exchanged between and among the affected agencies and notify the auditor of the determination.

(g) For the purpose of determining the amount of property tax to be allocated in the 1979–80 fiscal year and each fiscal year thereafter, for a city incorporation that was filed pursuant to Sections 54900 to 54904, inclusive, of the Government Code after January 1, 1978, but on or before January 1, 1979, the amount of property tax

revenue considered to have been received by the jurisdiction for the 1978–79 fiscal year shall be equal to two-thirds of the amount of property tax revenue projected in the final local agency formation commission staff report pertaining to the incorporation multiplied by the proportion that the total amount of property tax revenue received by all jurisdictions within the county for the 1978–79 fiscal year bears to the total amount of property tax revenue received by all jurisdictions within the county for the 1977–78 fiscal year. Except, however, in the event that the final commission report did not specify the amount of property tax revenue projected for that incorporation, the commission shall by October 10 determine pursuant to Section 54790.3 of the Government Code the amount of property tax to be transferred to the city.

The provisions of this subdivision shall also apply to the allocation of property taxes for the 1980–81 fiscal year and each fiscal year thereafter for incorporations approved by the voters in June 1979.

(h) For the purpose of the computations made pursuant to this section, in the case of a district formation that was filed pursuant to Sections 54900 to 54904, inclusive, of the Government Code after January 1, 1978, but before January 1, 1979, the amount of property tax to be allocated to the district for the 1979–80 fiscal year and each fiscal year thereafter shall be determined pursuant to Section 54790.3 of the Government Code.

(i) For the purposes of the computations required by this chapter, in the case of a jurisdictional change, other than a change requiring an adjustment by the auditor pursuant to subdivision (a), the auditor shall adjust the allocation of property tax revenue determined pursuant to Section 96 or 96.1 or its predecessor section, or the annual tax increment determined pursuant to Section 96.5 or its predecessor section, for each local school district, community college district, or county superintendent of schools whose service area or service responsibility would be altered by the jurisdictional change, as determined as follows:

(1) The governing body of each district, county superintendent of schools, or county whose service areas or service responsibilities would be altered by the change shall determine the amount of property tax revenues to be exchanged between and among the affected jurisdictions. This determination shall be adopted by each affected jurisdiction by resolution. For the purpose of negotiation, the county auditor shall furnish the parties and the county board of education with an estimate of the property tax revenue subject to negotiation.

(2) In the event that the affected jurisdictions are unable to agree, within 60 days after the effective date of the jurisdictional change, and if all the jurisdictions are wholly within one county, the county board of education shall, by resolution, determine the amount of property tax revenue to be exchanged. If the jurisdictions are in more than one county, the State Board of Education shall, by resolution, within 60 days after the effective date of the jurisdictional change, determine the amount of property tax to be exchanged.

(3) Upon adoption of any resolution pursuant to this subdivision, the adopting jurisdictions or State Board of Education shall notify the county auditor who shall make the appropriate adjustments as provided in subdivision (a).

(j) For purposes of subdivision (i), the annexation by a community college district of territory within a county not previously served by a community college district is an alteration of service area. The community college district and the county shall negotiate the amount, if any, of property tax revenues to be exchanged. In these negotiations, there shall be taken into consideration the amount of revenue received from the timber yield tax and forest reserve receipts by the community college district in the area not previously served. In no event shall the property tax revenue to be exchanged exceed the amount of property tax revenue collected prior to the annexation for the purposes of paying tuition expenses of residents enrolled in the community college district, adjusted each year by the percentage change in population and the percentage change in the cost of living, or per capita personal income, whichever is lower, less the amount of revenue received by the community college district in the annexed area from the timber yield tax and forest reserve receipts.

(k) At any time after a jurisdictional change is effective, any of the local agencies party to the agreement to exchange property tax revenue may renegotiate the agreement with respect to the current fiscal year or subsequent fiscal years, subject to approval by all local agencies affected by the renegotiation.

(Amended by Stats. 2015, Ch. 304, Sec. 22. (AB 851) Effective January 1, 2016.)



**South Lake County  
Fire Protection District  
Cost Accounting Management System  
Invoice Audit Trail**

*Detail Report by Vendor, Invoice*  
**Run Date: 12/11/2020 02:22:42pm By: GF**  
**Fiscal Year: 2021**

**Selection Criteria**

**Select Inv Batch No**  
12/15/20

**Report Template**

*AP Invoice Report Board Warrant List*  
\\Southlake\Lsladmin\Wincams\Lslfiles\Report\Criteria\AP Invoice Report Board Warrant List.rst

Voucher No	Merchant Vendor Name	Invoice Description	Line Item Description	Budget Exp Acct	Budget Rev Acct	Line Net Amt	Req No / Descr 2
ARBA001	VENDOR: ARBA						
8518JAN2021	INVOICE: GROUP LIFE FOR PCFS 12/03/20	STATUS: Printed					
10212	GROUP LIFE FOR PCFS	JAN 2021 ATKINS		357-9557-795-03-30-G		8.32	
10212	GROUP LIFE FOR PCFS	JAN 2021 CHASE		357-9557-795-03-30-G		8.32	
10212	GROUP LIFE FOR PCFS	JAN 2021 COLLINS		357-9557-795-03-30-G		8.32	
10212	GROUP LIFE FOR PCFS	JAN 2021 COSTA		357-9557-795-03-30-G		8.32	
10212	GROUP LIFE FOR PCFS	JAN 2021 DANIELS		357-9557-795-03-30-G		8.32	
10212	GROUP LIFE FOR PCFS	JAN 2021 DELONG		357-9557-795-03-30-G		8.32	
10212	GROUP LIFE FOR PCFS	JAN 2021 EMERSON		357-9557-795-03-30-G		8.32	
10212	GROUP LIFE FOR PCFS	JAN 2021 FANUCCHI		357-9557-795-03-30-G		8.32	
10212	GROUP LIFE FOR PCFS	JAN 2021 FENK		357-9557-795-03-30-G		8.32	
10212	GROUP LIFE FOR PCFS	JAN 2021 FLEENAR		357-9557-795-03-30-G		8.32	
10212	GROUP LIFE FOR PCFS	JAN 2021 PRAYER		357-9557-795-03-30-G		8.32	
10212	GROUP LIFE FOR PCFS	JAN 2021 HESS		357-9557-795-03-30-G		8.32	
10212	GROUP LIFE FOR PCFS	JAN 2021 HILDEBRAND		357-9557-795-03-30-G		8.32	
10212	GROUP LIFE FOR PCFS	JAN 2021 LANNING		357-9557-795-03-30-G		8.32	
10212	GROUP LIFE FOR PCFS	JAN 2021 LEUZINGER		357-9557-795-03-30-G		8.32	
10212	GROUP LIFE FOR PCFS	JAN 2021 LOPEZ		357-9557-795-03-30-G		8.32	
10212	GROUP LIFE FOR PCFS	JAN 2021 MCGEE		357-9557-795-03-30-G		8.32	
10212	GROUP LIFE FOR PCFS	JAN 2021 MIINCH		357-9557-795-03-30-G		8.32	
10212	GROUP LIFE FOR PCFS	JAN 2021 MYERS		357-9557-795-03-30-G		8.32	
10212	GROUP LIFE FOR PCFS	JAN 2021 NEWSOM		357-9557-795-03-30-G		8.32	
10212	GROUP LIFE FOR PCFS	JAN 2021 PARROTT		357-9557-795-03-30-G		8.32	
10212	GROUP LIFE FOR PCFS	JAN 2021 RYON		357-9557-795-03-30-G		8.32	
10212	GROUP LIFE FOR PCFS	JAN 2021 SMITH		357-9557-795-03-30-G		8.32	
10212	GROUP LIFE FOR PCFS	JAN 2021 TOTAGRANDE		357-9557-795-03-30-G		8.32	
10212	GROUP LIFE FOR PCFS	DEC 2020 VARGAS		357-9557-795-03-30-G		-8.32	
* 8518JAN2021 Subtotal						191.36	
** ARBA001 Subtotal (1 Invoice)						191.36	
CALL001	VENDOR: CALLAYOMI CO WATER DISTRICT						
80 113020	INVOICE: WATER 12/04/20	STATUS: Printed					
10213	WATER	STA 60 ME 11/30/20 (19650)		357-9557-795-30-00-WF		558.19	
* 80 113020 Subtotal						558.19	
81 113020	INVOICE: WATER 12/04/20	STATUS: Printed					
10213	WATER	FS Bldg ME 11/30/20 (1854)		357-9557-795-30-00-WF		43.38	
* 81 113020 Subtotal						43.38	
** CALL001 Subtotal (2 Invoices)						601.57	
COUN002	VENDOR: COUNTY OF LAKE SOLID WASTE						
04-00437722	INVOICE: GARBAGE DISPOSAL 12/07/20	STATUS: Printed					
10214	GARBAGE DISPOSAL	FS BLDG (520 LB)		357-9557-795-30-00-GF		16.46	
* 04-00437722 Subtotal						16.46	
** COUN002 Subtotal (1 Invoice)						16.46	
DEPT002	VENDOR: DEPARTMENT OF HEALTH CARE SERVICES						
GEM01213W10	INVOICE: GEMT QAF 2020 Q1 11/25/20	STATUS: Printed					
10215	GEMT QAF 2020 Q1	MEDI-CAL FEE FOR SERVICE		357-9557-795-28-48-GE		96.90	
10215	GEMT QAF 2020 Q1	MEDI-CAL MANAGED CARE		357-9557-795-28-48-GE		678.30	
10215	GEMT QAF 2020 Q1	MEDICARE		357-9557-795-28-48-GE		1,195.10	
10215	GEMT QAF 2020 Q1	OTHER		357-9557-795-28-48-GE		323.00	
10215	GEMT QAF 2020 Q1	DUAL MEDICARE/MEDI-CAL		357-9557-795-28-48-GE		872.10	
* GEM01213W10 Subtotal						3,165.40	
GEM02211NI5	INVOICE: GEMT QAF 2020 Q2 11/25/20	STATUS: Printed					
10215	GEMT QAF 2020 Q2	MEDI-CAL MANAGED CARE		357-9557-795-28-48-GE		549.10	
10215	GEMT QAF 2020 Q2	MEDICARE		357-9557-795-28-48-GE		1,098.20	
10215	GEMT QAF 2020 Q2	OTHER		357-9557-795-28-48-GE		290.70	
10215	GEMT QAF 2020 Q2	DUAL MEDICARE/MEDI-CAL		357-9557-795-28-48-GE		775.20	
* GEM02211NI5 Subtotal						2,713.20	
** DEPT002 Subtotal (2 Invoices)						5,878.60	
LAKE001	VENDOR: LAKE COUNTY EMPLOYEES' ASSN						
HORST JAN 2021	INVOICE: OPEB 01/01/21	STATUS: Printed					
10216	OPEB	JAN 2021 - HORST DUES		357-9557-795-03-30-R		31.64	
* HORST JAN 2021 Subtotal						31.64	
** LAKE001 Subtotal (1 Invoice)						31.64	
LIFE001	VENDOR: LIFE ASSIST INC						
1050096	INVOICE: EMS SUPPLIES 11/12/20	STATUS: Printed					
10217	EMS SUPPLIES	PO 1122521		357-9557-795-19-40-MS		1,034.06	
* 1050096 Subtotal						1,034.06	
1051773	INVOICE: EMS SUPPLIES 11/18/20	STATUS: Printed					
10217	EMS SUPPLIES	PO 1122521		357-9557-795-19-40-MS		28.85	
* 1051773 Subtotal						28.85	
1057248	INVOICE: EMS SUPPLIES 12/09/20	STATUS: Printed					
10217	EMS SUPPLIES	ORDER 112522		357-9557-795-19-40-MS		1,860.78	
* 1057248 Subtotal						1,860.78	
** LIFE001 Subtotal (3 Invoices)						2,923.69	
LONGNATHAN	VENDOR: NATHAN LONG						
OBP1401	INVOICE: REFUND OBP1401 11/25/20	STATUS: Printed					
10219	REFUND OBP1401	REFUND OBP1401			357-9557-422-21-60-00	28.00	
* OBP1401 Subtotal						28.00	
** LONGNATHAN Subtotal (1 Invoice)						28.00	
MERR001	VENDOR: MERRILL ARNONE & JONES LLP						
1220051	INVOICE: LEGAL EXPENSES 12/01/20	STATUS: Printed					
10218	LEGAL EXPENSES	ME 11/30/20		357-9557-795-23-80-SP		33.00	
* 1220051 Subtotal						33.00	

Voucher No	Merchant Vendor Name	Invoice Description	Line Item Description	Budget Exp Acct	Budget Rev Acct	Line Net Amt	Req No / Descr 2
MERR001	VENDOR: MERRILL ARNONE & JONES LLP						
1220052	INVOICE: LEGAL EXPENSES 12/01/20	STATUS: Printed					
10218		LEGAL EXPENSES	PACIFIC REGION OPEN BIBLE CV-421176	357-9557-795-23-80-SF		2,100.00	
	<b>* 1220052 Subtotal</b>					<b>2,100.00</b>	
	<b>** MERR001 Subtotal (2 Invoices)</b>					<b>2,133.00</b>	
NORT001	VENDOR: NORTH COAST EMS						
0101-063020CORR	INVOICE: IMAGE TREND ELITE 10/16/20	STATUS: Printed					
10220		IMAGE TREND ELITE	JAN-JUNE 2020	357-9557-795-28-48-NC		326.00	
	<b>* 0101-063020CORR Subtotal</b>					<b>326.00</b>	
	<b>** NORT001 Subtotal (1 Invoice)</b>					<b>326.00</b>	
OPER001	VENDOR: OPERATING ENGINEERS						
HORST JAN 2021	INVOICE: OPEB 01/01/21	STATUS: Printed					
10221		OPEB	JAN 2021 - HORST HEALTH INS	357-9557-795-03-30-R		1,777.00	
	<b>* HORST JAN 2021 Subtotal</b>					<b>1,777.00</b>	
	<b>** OPER001 Subtotal (1 Invoice)</b>					<b>1,777.00</b>	
PG&E001	VENDOR: PG&E						
69913707415 1119	INVOICE: ELECTRIC CHGS 11/20/20	STATUS: Printed					
10222		ELECTRIC CHGS	STA 62 ME 11/19/20 (2414.557500 kWh)	357-9557-795-30-00-E2		595.02	
10222		ELECTRIC CHGS	FS Bldg ME 11/19/20 (707.346500 kWh)	357-9557-795-30-00-EF		195.90	
10222		ELECTRIC CHGS	STA 64 ME 11/19/20 (367.205000 kWh)	357-9557-795-30-00-E4		112.96	
10222		ELECTRIC CHGS	STA 60 ME 11/16/20 (4701.640000 kWh)	357-9557-795-30-00-E0		1,109.25	
10222		ELECTRIC CHGS	STA 63 ME 11/19/20 (1681.070000 kWh)	357-9557-795-30-00-E3		419.67	
	<b>* 69913707415 1119 Subtotal</b>					<b>2,432.80</b>	
	<b>** PG&amp;E001 Subtotal (1 Invoice)</b>					<b>2,432.80</b>	
RESO001	VENDOR: RESOLVE INSURANCE SYSTEMS						
OCTOBER 2020	INVOICE: AMBULANCE BILLING SV 11/01/20	STATUS: Printed					
10223		AMBULANCE BILLING SVC	01/02/19 1900098 W/O 07/16/19 30% O	357-9557-795-23-80-AB		870.90	
	<b>* OCTOBER 2020 Subtotal</b>					<b>870.90</b>	
	<b>** RESO001 Subtotal (1 Invoice)</b>					<b>870.90</b>	
USBA001	VENDOR: US BANK						
0020-0293 CORR	INVOICE: FORCE ENTRY TRAIN DO 10/28/20	STATUS: Printed					
10225		FORCIBLE ENTRY EQUIPMENT	FORCE ENTRY TRAIN DOOR	357-9557-795-18-00-T		6,554.63	FIRE SIREN WISHLIST 2020
	<b>* 0020-0293 CORR Subtotal</b>					<b>6,554.63</b>	
0020-0293 CR	INVOICE: FORCE ENTRY TRAIN DO 10/28/20	STATUS: Printed					
10225		FORCIBLE ENTRY EQUIPMENT	FORCE ENTRY TRAIN DOOR	357-9557-795-18-00-T		-6,484.63	FIRE SIREN WISHLIST 2020
	<b>* 0020-0293 CR Subtotal</b>					<b>-6,484.63</b>	
04-105393	INVOICE: OFFICE SUPPLIES 11/10/20	STATUS: Printed					
10225		HARDESTERS	STA 62 HARDWARE	357-9557-795-22-70-62		4.25	
	<b>* 04-105393 Subtotal</b>					<b>4.25</b>	
16719	INVOICE: BAY DOOR REPAIR (2) 11/18/20	STATUS: Printed					
10225		JERI-CO GARAGE DOORS & OPERATIONS	BAY DOOR REPAIR (2)	357-9557-795-18-00-60		1,489.50	
10225		JERI-CO GARAGE DOORS & OPERATIONS	BAY DOOR REPAIR (2)	357-9557-795-18-00-60		2,000.00	
10225		JERI-CO GARAGE DOORS & OPERATIONS	BAY DOOR REPAIR (2)	357-9557-795-18-00-60		1,800.00	
	<b>* 16719 Subtotal</b>					<b>5,289.50</b>	
16723	INVOICE: PREVENTATIVE MAINT 11/18/20	STATUS: Printed					
10225		JERI-CO GARAGE DOORS & OPERATIONS	PREVENTATIVE MAINT	BI-ANNUAL	357-9557-795-18-00-60	210.00	
	<b>* 16723 Subtotal</b>					<b>210.00</b>	
	<b>** USBA001 Subtotal (5 Invoices)</b>					<b>5,573.75</b>	
USBA002	VENDOR: U.S.BANK						
02-116796 113020	INVOICE: REFUSE/RECYCLE COLLE 11/30/20	STATUS: Approved					
	SOUTH LAKE REFUSE	REFUSE/RECYCLE COLLECTION	STA 62 ME 11/30/20	357-9557-795-30-00-G2		68.73	
	<b>* 02-116796 113020 Subtotal</b>					<b>68.73</b>	
02-152940 113020	INVOICE: REFUSE/RECYCLE COLLE 11/30/20	STATUS: Approved					
	SOUTH LAKE REFUSE	REFUSE/RECYCLE COLLECTION	STA 60 ME 11/30/20	357-9557-795-30-00-G0		303.42	
	<b>* 02-152940 113020 Subtotal</b>					<b>303.42</b>	
02-601722 113020	INVOICE: REFUSE/RECYCLE COLLE 11/30/20	STATUS: Approved					
	SOUTH LAKE REFUSE	REFUSE/RECYCLE COLLECTION	STA 63 ME 11/30/20	357-9557-795-30-00-G3		81.42	
	<b>* 02-601722 113020 Subtotal</b>					<b>81.42</b>	
1113285745	INVOICE: PROPANE 10/28/20	STATUS: Approved					
	FERRELLGAS	PROPANE	STA 62 FILL 10/28/20	357-9557-795-30-00-P2		402.57	
	<b>* 1113285745 Subtotal</b>					<b>402.57</b>	
1113622426	INVOICE: PROPANE 11/22/20	STATUS: Approved					
	FERRELLGAS	PROPANE	STA 60 FILL 11/22/20	357-9557-795-30-00-P0		756.20	
	<b>* 1113622426 Subtotal</b>					<b>756.20</b>	
22680641	INVOICE: MEDICAL OXYGEN RENTA 11/30/20	STATUS: Approved					
	MATHESON TRI-GAS INC	MEDICAL OXYGEN RENTAL	ME 11/30/20	357-9557-795-19-40-0		32.45	
	<b>* 22680641 Subtotal</b>					<b>32.45</b>	
232491	INVOICE: RADIO INSTALLATION 11/25/20	STATUS: Approved					
	FISHER WIRELESS SERVICES INC	RADIO INSTALLATION	M6311 450-470 NO GROUND PLANE	357-9557-795-28-48-63		52.43	
	FISHER WIRELESS SERVICES INC	RADIO INSTALLATION	M6311 TK790/890 MOUNTING BRACKET	357-9557-795-28-48-63		58.85	
	FISHER WIRELESS SERVICES INC	RADIO INSTALLATION	M6311 INSTALLATION HARDWARE KIT	357-9557-795-28-48-63		16.05	
	FISHER WIRELESS SERVICES INC	RADIO INSTALLATION	M6311 LABOR	357-9557-795-28-48-63		65.00	
	FISHER WIRELESS SERVICES INC	RADIO INSTALLATION	M6311 TRAVEL TIME	357-9557-795-28-48-63		902.50	
	<b>* 232491 Subtotal</b>					<b>1,094.83</b>	
261580	INVOICE: EMS SUPPLIES 10/28/20	STATUS: Approved					
	BWS DISTRIBUTORS INC	EMS SUPPLIES	DISP N-95 DUST/MIST RESP	357-9557-795-19-40-MS		369.51	
	<b>* 261580 Subtotal</b>					<b>369.51</b>	

Voucher No	Merchant Vendor Name	Invoice Description	Line Item Description	Budget Exp Acct	Budget Rev Acct	Line Net Amt	Req No / Descr 2
USBA002	VENDOR: U.S.BANK						
3005329200	INVOICE: MEDICAL WASTE DISPOS STERICYCLE INC	11/09/20 STATUS: Approved MEDICAL WASTE DISPOSAL	ME 11/30/20	357-9557-795-19-40-MW		87.05 <b>87.05</b>	
<b>* 3005329200 Subtotal</b>							
3005340105	INVOICE: MEDICAL WASTE DISPOS STERICYCLE INC	11/23/20 STATUS: Approved MEDICAL WASTE DISPOSAL	COLLECTED 11/16/20	357-9557-795-19-40-MW		0.09 <b>0.09</b>	
<b>* 3005340105 Subtotal</b>							
3005368929	INVOICE: MEDICAL WASTE DISPOS STERICYCLE INC	12/07/20 STATUS: Approved MEDICAL WASTE DISPOSAL	ME 12/31/20	357-9557-795-19-40-MW		87.05 <b>87.05</b>	
<b>* 3005368929 Subtotal</b>							
30128147	121620 INVOICE: INTERNET SVC MEDIACOM	11/07/20 STATUS: Approved INTERNET SVC	STA 63 ME 12/16/20	357-9557-795-30-00-I3		68.18 <b>68.18</b>	
<b>* 30128147 121620 Subtotal</b>							
30165883	122620 INVOICE: INTERNET SVC MEDIACOM	11/17/20 STATUS: Approved INTERNET SVC	STA 62 ME 12/26/20 STA 62 OVERAGE ME 11/26/20	357-9557-795-30-00-I2 357-9557-795-30-00-I2		68.18 40.00 <b>108.18</b>	
<b>* 30165883 122620 Subtotal</b>							
30173705	122620 INVOICE: INTERNET SVC MEDIACOM	11/17/20 STATUS: Approved INTERNET SVC	STA 60 ME 12/26/20	357-9557-795-30-00-I0		57.99 <b>57.99</b>	
<b>* 30173705 122620 Subtotal</b>							
322052	INVOICE: TRAINING SUPPLIES,SU SUPPLYCACHE.COM	12/07/20 STATUS: Approved TRAINING SUPPLIES,SUPPORT FF ACADEM	FIRE HOSE SHUT-OFF CLAMP TIMBERLINE	357-9557-795-28-30-TB		1,317.21 <b>1,317.21</b>	CAL FIRE TRAINING BUREAU FUNDS
<b>* 322052 Subtotal</b>							
41821	INVOICE: GENERATOR HISTORY LO LEETE GENERATORS	11/08/20 STATUS: Approved GENERATOR HISTORY LOG	200.1 HRS 10/01/20	357-9557-795-18-00-60		170.00 <b>170.00</b>	FEMA D44240 PW #49
<b>* 41821 Subtotal</b>							
41822	INVOICE: GENERATOR HISTORY LO LEETE GENERATORS	11/08/20 STATUS: Approved GENERATOR HISTORY LOG	220.0 HRS 10/01/20	357-9557-795-18-00-62		170.00 <b>170.00</b>	FEMA D44240 PW #49
<b>* 41822 Subtotal</b>							
41823	INVOICE: GENERATOR HISTORY LO LEETE GENERATORS	11/08/20 STATUS: Approved GENERATOR HISTORY LOG	193.7 HRS 10/01/20	357-9557-795-18-00-63		170.00 <b>170.00</b>	FEMA D44240 PW #49
<b>* 41823 Subtotal</b>							
41824	INVOICE: GENERATOR HISTORY LO LEETE GENERATORS	11/08/20 STATUS: Approved GENERATOR HISTORY LOG	109.1 HRS 10/01/20	357-9557-795-18-00-64		170.00 <b>170.00</b>	FEMA D44240 PW #49
<b>* 41824 Subtotal</b>							
447530	INVOICE: APPLIANCE REPL, SECU HARDESTERS	11/14/20 STATUS: Approved APPLIANCE REPL, SECURITY ITEM	STA 63 TOASTER 2SLT BLK PL STA 60 PADLOCK LAMI-3/4PIN	357-9557-795-14-00-63 357-9557-795-14-00-60		21.44 10.71 <b>32.15</b>	
<b>* 447530 Subtotal</b>							
448252	INVOICE: HORN STRUCTURE FIRE HARDESTERS	11/12/20 STATUS: Approved HORN STRUCTURE FIRE	E1487 MEALS E1477 MEALS OES359 MEALS R6031 MEALS M6211 MEALS	357-9557-795-13-00-63 357-9557-795-13-00-63 357-9557-795-13-00-63 357-9557-795-13-00-63 357-9557-795-13-00-63		24.63 24.60 16.42 16.40 16.40 <b>98.45</b>	
<b>* 448252 Subtotal</b>							
448351	INVOICE: MOUNT HOSE ROOM REEL HARDESTERS	11/02/20 STATUS: Approved MOUNT HOSE ROOM REELS	STA 60 FASTENERS STA 60 BIT DRILL TURBOMAX STA 60 PUNCH CENTER #77 STA 60 VELCRO TAPE 5' STICKY STA 60 BIT DRILL ROTARY 1/2	357-9557-795-18-00-60 357-9557-795-18-00-60 357-9557-795-18-00-60 357-9557-795-18-00-60 357-9557-795-18-00-60		24.13 4.28 16.08 12.86 7.06 <b>64.41</b>	
<b>* 448351 Subtotal</b>							
448397	INVOICE: CLEANING SUPPLIES HARDESTERS	11/13/20 STATUS: Approved CLEANING SUPPLIES	STA 62 SOS HD SCRUBBER STA 62 VEGGIE SCRUBBER STA 62 PLATES (26 CT)	357-9557-795-14-00-62 357-9557-795-14-00-62 357-9557-795-14-00-62		5.96 3.64 4.60 <b>14.20</b>	
<b>* 448397 Subtotal</b>							
449442	INVOICE: COMPRESSOR REPL INSTL HARDESTERS	11/03/20 STATUS: Approved COMPRESSOR REPL INSTL PARTS	STA 60 FIX IT ALL PATCH 4.5 STA 60 LQD NAILS XTREM HD STA 60 CAULKGUN SMOOTHROD3 STA 60 HEX BUSH 3/8MX1/4 STA 60 AIR PLUG I/M 1/4 MNP STA 60 HARDWARE	357-9557-795-17-00-60 357-9557-795-17-00-60 357-9557-795-17-00-60 357-9557-795-17-00-60 357-9557-795-17-00-60 357-9557-795-17-00-60		8.57 5.35 5.99 3.85 3.21 9.40 <b>36.37</b>	
<b>* 449442 Subtotal</b>							
449537	INVOICE: INTERIOR LIGHT FIXTU HARDESTERS	11/04/20 STATUS: Approved INTERIOR LIGHT FIXTURE REPR	STA 64 CEL FLUSH BRZ 11W STA 64 LED FEIT A19 60W EQ STA 64 WALLPLAT1G GFICI DECO	357-9557-795-18-00-64 357-9557-795-18-00-64 357-9557-795-18-00-64		45.04 32.15 1.49 <b>78.68</b>	
<b>* 449537 Subtotal</b>							
449806	INVOICE: DISHWASHER REPL INST HARDESTERS	11/25/20 STATUS: Approved DISHWASHER REPL INSTL PARTS	STA 62 WALLPLAT1G GFICI DECO STA 62 AIR GAP 5/8X7/8	357-9557-795-18-00-62 357-9557-795-18-00-62		1.49 9.21 <b>10.70</b>	
<b>* 449806 Subtotal</b>							
451302	INVOICE: CLEANING SUPPLIES HARDESTERS	11/21/20 STATUS: Approved CLEANING SUPPLIES	STA 60 CLEANR FLR WOOD BONA	357-9557-795-14-00-60		25.72	

Voucher No	Merchant Vendor Name	Invoice Description	Line Item Description	Budget Exp Acct	Budget Rev Acct	Line Net Amt	Req No / Descr 2
USBA002	VENDOR: U.S.BANK						
451302	INVOICE: CLEANING SUPPLIES 11/21/20	STATUS: Approved					
	HARDESTERS	CLEANING SUPPLIES	STA 60 PAD MOP MICROPLUS	357-9557-795-14-00-60		10.72	
	HARDESTERS	CLEANING SUPPLIES	STA 60 PRIMRSPLY AUTO SELF	357-9557-795-14-00-60		6.42	
<b>* 451302 Subtotal</b>						<b>42.86</b>	
455740	INVOICE: HVAC ITEM 11/19/20	STATUS: Approved					
	HARDESTERS	HVAC ITEM	STA 63 AIR FILTERS 14X14	357-9557-795-18-00-63		48.17	
<b>* 455740 Subtotal</b>						<b>48.17</b>	
455742	INVOICE: REPLACEMENT LIGHT BU 11/19/20	STATUS: Approved					
	HARDESTERS	REPLACEMENT LIGHT BULBS	STA 63 LED FEIT PAR20 50W	357-9557-795-14-00-63		7.50	
<b>* 455742 Subtotal</b>						<b>7.50</b>	
50050000 113020	INVOICE: WATER/SEWER 12/01/20	STATUS: Approved					
	HIDDEN VALLEY LAKE CSD	WATER/SEWER	STA 63 WATER ME 11/30/20 (533)	357-9557-795-30-00-W3		53.86	
	HIDDEN VALLEY LAKE CSD	WATER/SEWER	STA 63 SEWER ME 11/30/20	357-9557-795-30-00-W3		64.94	
<b>* 50050000 113020 Subtotal</b>						<b>118.80</b>	
50227	INVOICE: PEST CONTROL 11/20/20	STATUS: Approved					
	ARMED FORCE PEST CONTROL	PEST CONTROL	TRNG TWR SPIDER	357-9557-795-18-00-T		225.00	
<b>* 50227 Subtotal</b>						<b>225.00</b>	
50732	INVOICE: PEST CONTROL 12/07/20	STATUS: Approved					
	ARMED FORCE PEST CONTROL	PEST CONTROL	STA 63 RODENT BAIT STATION	357-9557-795-18-00-63		20.00	
<b>* 50732 Subtotal</b>						<b>20.00</b>	
5996948	INVOICE: HT RADIO REPAIR 10/13/20	STATUS: Approved					
	BK TECHNOLOGIES INC	HT RADIO REPAIR	SPARE RADIOS	357-9557-795-12-00-60		1,200.00	
<b>* 5996948 Subtotal</b>						<b>1,200.00</b>	
61732	INVOICE: HYDRATION FOR STA 10/09/20	STATUS: Approved					
	ICE WATER CO	HYDRATION FOR STA	STA 60 BOTTLED WATER	357-9557-795-13-00-60		6.25	
<b>* 61732 Subtotal</b>						<b>6.25</b>	
62612	INVOICE: HYDRATION FOR STA 11/20/20	STATUS: Approved					
	ICE WATER CO	HYDRATION FOR STA	STA 60 BOTTLED WATER	357-9557-795-13-00-60		6.25	
	ICE WATER CO	HYDRATION FOR STA	STA 62 BOTTLED WATER	357-9557-795-13-00-62		6.25	
	ICE WATER CO	HYDRATION FOR STA	STA 63 BOTTLED WATER	357-9557-795-13-00-63		6.25	
<b>* 62612 Subtotal</b>						<b>18.75</b>	
8274	INVOICE: ANNUAL RENEWAL 11/20/20	STATUS: Approved					
	LCW COMPUTER REPAIR	ANNUAL RENEWAL	HOSTING PACKAGE,DOMAIN RENEWAL	357-9557-795-28-30-L		144.00	
	LCW COMPUTER REPAIR	ANNUAL RENEWAL	DOMAIN RENEWAL	357-9557-795-28-30-L		18.00	
<b>* 8274 Subtotal</b>						<b>162.00</b>	
840-59400166	INVOICE: POSTAGE 11/24/20	STATUS: Approved					
	US POSTAL SERVICE	POSTAGE	US FLAG COIL/100	357-9557-795-22-71-60		110.00	
<b>* 840-59400166 Subtotal</b>						<b>110.00</b>	
9718177836	INVOICE: PPE,LOGISTICS SUPPLI 11/16/20	STATUS: Approved					
	GRAINGER	PPE,LOGISTICS SUPPLIES	TOILET PAPER ROLL 1000 WHITE PK 96	357-9557-795-14-00-60		1,031.69	COVID-19
	GRAINGER	PPE,LOGISTICS SUPPLIES	PAPER TOWEL ROLL 250 WHITE PK 12	357-9557-795-14-00-60		285.07	COVID-19
<b>* 9718177836 Subtotal</b>						<b>1,316.76</b>	
9867922395	INVOICE: CELLULAR SVC 11/26/20	STATUS: Approved					
	VERIZON WIRELESS	CELLULAR SVC	M6211 ME 12/26/20 Booster Extender	357-9557-795-12-00-62		38.01	
	VERIZON WIRELESS	CELLULAR SVC	M6211 ME 12/26/20 Booster Extender	357-9557-795-12-00-62		38.01	
	VERIZON WIRELESS	CELLULAR SVC	M6311 ME 12/26/20 Booster Extender	357-9557-795-12-00-63		46.61	
	VERIZON WIRELESS	CELLULAR SVC	M6011 ME 12/26/20 Booster Extender	357-9557-795-12-00-60		38.01	
	VERIZON WIRELESS	CELLULAR SVC	B1417 ME 12/26/20 Tablet	357-9557-795-12-00-A		16.02	
	VERIZON WIRELESS	CELLULAR SVC	B1418 ME 12/26/20 Tablet	357-9557-795-12-00-A		16.02	
	VERIZON WIRELESS	CELLULAR SVC	M6011 ME 12/26/20 Tablet	357-9557-795-12-00-60		16.02	
	VERIZON WIRELESS	CELLULAR SVC	E1487 ME 12/26/20 Tablet	357-9557-795-12-00-A		16.02	
	VERIZON WIRELESS	CELLULAR SVC	M6311 ME 12/26/20 Tablet	357-9557-795-12-00-63		16.02	
	VERIZON WIRELESS	CELLULAR SVC	M6012 ME 12/26/20 Cell Phone	357-9557-795-12-00-60		0.53	
	VERIZON WIRELESS	CELLULAR SVC	OES359 ME 12/26/20 Cell Phone	357-9557-795-12-00-60		0.53	
	VERIZON WIRELESS	CELLULAR SVC	Spare ME 12/26/20 Cell Phone	357-9557-795-12-00-60		0.53	
	VERIZON WIRELESS	CELLULAR SVC	M6011 ME 12/26/20 Cell Phone	357-9557-795-12-00-60		0.53	
	VERIZON WIRELESS	CELLULAR SVC	M6211 ME 12/26/20 Cell Phone	357-9557-795-12-00-62		0.53	
	VERIZON WIRELESS	CELLULAR SVC	M6311 ME 12/26/20 Cell Phone	357-9557-795-12-00-63		0.53	
<b>* 9867922395 Subtotal</b>						<b>243.92</b>	
BFF953D6-001	INVOICE: ANNUAL SUBSCRIPTION 12/04/20	STATUS: Approved					
	JOTFORM INC	ANNUAL SUBSCRIPTION	ONLINE FORM BUILDER	357-9557-795-28-30-L		234.00	
<b>* BFF953D6-001 Subtotal</b>						<b>234.00</b>	
OLO1	INVOICE: MEALS (4) 11/25/20	STATUS: Approved					
	PERRYS DELI	MEALS (4)	LAKE COUNTY CHIEFS MEETING	357-9557-795-13-00-60		34.16	
<b>* OLO1 Subtotal</b>						<b>34.16</b>	
ORDER4683	INVOICE: TRAINING SUPPLIES,SU 12/07/20	STATUS: Approved					
	CASCADE FIRE EQUIPMENT COMPANY	TRAINING SUPPLIES,SUPPORT FF ACADEM	VEHICLE BRACKET	357-9557-795-28-30-TB		146.14	CAL FIRE TRAINING BUREAU FUNDS
	CASCADE FIRE EQUIPMENT COMPANY	TRAINING SUPPLIES,SUPPORT FF ACADEM	HOSE ROLLER W/QUICK MOUNT BRACKET	357-9557-795-28-30-TB		706.89	CAL FIRE TRAINING BUREAU FUNDS
<b>* ORDER4683 Subtotal</b>						<b>853.03</b>	
S0602284	INVOICE: REPL FIRE HOSE 11/18/20	STATUS: Approved					
	LN CURTIS & SONS	REPL FIRE HOSE	E6221 3X25' CPLD 2.5NH RED DB8000 D	357-9557-795-28-30-62		219.59	
	LN CURTIS & SONS	REPL FIRE HOSE	WT6411 3X25' CPLD 2.5NH RED DB8000	357-9557-795-28-30-64		219.59	
	LN CURTIS & SONS	REPL FIRE HOSE	STA 62 3X25' CPLD 2.5NH RED DB8000	357-9557-795-28-30-62		439.18	
<b>* S0602284 Subtotal</b>						<b>878.36</b>	
<b>** USBA002 Subtotal (43 Invoices)</b>						<b>11,369.40</b>	

Voucher No	Merchant Vendor Name	Invoice Description	Line Item Description	Budget Exp Acct	Budget Rev Acct	Line Net Amt	Req No / Descr 2
USBA003	VENDOR: US BANK VOYAGER FLEET SYS						
86903725048	INVOICE: FUEL-GLASS FIRE 11/24/20	STATUS: Printed					
10224		FUEL-GLASS FIRE	U1426 10/30/20	357-9557-795-29-50-C		57.76	
	<b>* 86903725048 Subtotal</b>					<b>57.76</b>	
	<b>** USBA003 Subtotal (1 Invoice)</b>					<b>57.76</b>	
WITT001	VENDOR: WITTMAN ENTERPRISES						
20010043	INVOICE: AMBULANCE BILLING SV 11/17/20	STATUS: Printed					
10226		AMBULANCE BILLING SVC	OCTOBER 2020	357-9557-795-23-80-AB		3,465.00	
	<b>* 20010043 Subtotal</b>					<b>3,465.00</b>	
	<b>** WITT001 Subtotal (1 Invoice)</b>					<b>3,465.00</b>	
	<b>*** Grand Total (67 Invoices)</b>					<b>37,676.93</b>	

**South Lake County  
Fire Protection District  
Cost Accounting Management System  
Invoice Audit Trail**

*Detail Report by Vendor, Invoice*  
**Run Date: 12/11/2020 02:05:56pm By: GF**  
**Fiscal Year: 2021**

**Selection Criteria**

**Select Inv Batch No**  
11/17/20

**Report Template**

*AP Invoice Report Board Warrant List*  
\\Southlake\Lsladmin\Wincams\Lslfiles\Report\Criteria\AP Invoice Report Board Warrant List.rst

Voucher No	Merchant Vendor Name	Invoice Description	Line Item Description	Budget Exp Acct	Budget Rev Acct	Line Net Amt	Req No / Descr 2
AIRINSTRUM VENDOR: AIR INSTRUMENTATION OF CALIF							
0020721	INVOICE: CO MONITOR REPLACEME 11/06/20	STATUS: Printed					
10190		CO MONITOR REPLACEMENT	STA 62 MONITOR 3 YR LEASE	357-9557-795-17-00-62		1,352.40	
10190		CO MONITOR REPLACEMENT	STA 62 CALIBRATION STA 3 YR LEASE	357-9557-795-17-00-62		1,347.22	
10190		CO MONITOR REPLACEMENT	STA 63 MONITOR 3 YR LEASE	357-9557-795-17-00-63		1,352.40	
10190		CO MONITOR REPLACEMENT	STA 63 CALIBRATION STA 3 YR LEASE	357-9557-795-17-00-63		1,347.21	
* 0020721 Subtotal						<u>5,399.23</u>	
** AIRINSTRUM Subtotal (1 Invoice)						<b>5,399.23</b>	
ARBA001 VENDOR: ARBA							
8518DEC2020	INVOICE: GROUP LIFE FOR PCFS 11/03/20	STATUS: Printed					
10191		GROUP LIFE FOR PCFS	DEC 2020 ATKINS	357-9557-795-03-30-G		8.32	
10191		GROUP LIFE FOR PCFS	DEC 2020 CHASE	357-9557-795-03-30-G		8.32	
10191		GROUP LIFE FOR PCFS	DEC 2020 COLLINS	357-9557-795-03-30-G		8.32	
10191		GROUP LIFE FOR PCFS	DEC 2020 COSTA	357-9557-795-03-30-G		8.32	
10191		GROUP LIFE FOR PCFS	DEC 2020 DANIELS	357-9557-795-03-30-G		8.32	
10191		GROUP LIFE FOR PCFS	DEC 2020 DELONG	357-9557-795-03-30-G		8.32	
10191		GROUP LIFE FOR PCFS	DEC 2020 EMERSON	357-9557-795-03-30-G		8.32	
10191		GROUP LIFE FOR PCFS	DEC 2020 FANUCCHI	357-9557-795-03-30-G		8.32	
10191		GROUP LIFE FOR PCFS	DEC 2020 FENK	357-9557-795-03-30-G		8.32	
10191		GROUP LIFE FOR PCFS	DEC 2020 FLEENAR	357-9557-795-03-30-G		8.32	
10191		GROUP LIFE FOR PCFS	DEC 2020 FRAYER	357-9557-795-03-30-G		8.32	
10191		GROUP LIFE FOR PCFS	DEC 2020 HESS	357-9557-795-03-30-G		8.32	
10191		GROUP LIFE FOR PCFS	DEC 2020 HILDEBRAND	357-9557-795-03-30-G		8.32	
10191		GROUP LIFE FOR PCFS	DEC 2020 LANNING	357-9557-795-03-30-G		8.32	
10191		GROUP LIFE FOR PCFS	DEC 2020 LEUZINGER	357-9557-795-03-30-G		8.32	
10191		GROUP LIFE FOR PCFS	DEC 2020 LOPEZ	357-9557-795-03-30-G		8.32	
10191		GROUP LIFE FOR PCFS	DEC 2020 MCGEE	357-9557-795-03-30-G		8.32	
10191		GROUP LIFE FOR PCFS	DEC 2020 MIINCH	357-9557-795-03-30-G		8.32	
10191		GROUP LIFE FOR PCFS	DEC 2020 MYERS	357-9557-795-03-30-G		8.32	
10191		GROUP LIFE FOR PCFS	DEC 2020 NEWSOM	357-9557-795-03-30-G		8.32	
10191		GROUP LIFE FOR PCFS	DEC 2020 PARROTT	357-9557-795-03-30-G		8.32	
10191		GROUP LIFE FOR PCFS	DEC 2020 RYON	357-9557-795-03-30-G		8.32	
10191		GROUP LIFE FOR PCFS	DEC 2020 SMITH	357-9557-795-03-30-G		8.32	
10191		GROUP LIFE FOR PCFS	DEC 2020 TOTAGRANDE	357-9557-795-03-30-G		8.32	
10191		GROUP LIFE FOR PCFS	DEC 2020 VARGAS	357-9557-795-03-30-G		8.32	
* 8518DEC2020 Subtotal						<u>208.00</u>	
** ARBA001 Subtotal (1 Invoice)						<b>208.00</b>	
AT&T001 VENDOR: AT&T							
15612851	INVOICE: TELEPHONE CHGS 11/13/20	STATUS: Printed					
10192		TELEPHONE CHGS	STA 64 ME 10/13/20	357-9557-795-30-00-T4		23.61	
10192		TELEPHONE CHGS	STA 62 ME 10/13/20	357-9557-795-30-00-T2		52.96	
10192		TELEPHONE CHGS	STA 63 ME 10/13/20	357-9557-795-30-00-T3		51.35	
10192		TELEPHONE CHGS	STA 60 ME 10/13/20	357-9557-795-30-00-T0		169.45	
10192		TELEPHONE CHGS	FS Bldg ME 10/13/20	357-9557-795-30-00-TF		21.96	
* 15612851 Subtotal						<u>319.33</u>	
** AT&T001 Subtotal (1 Invoice)						<b>319.33</b>	
CALL001 VENDOR: CALLAYOMI CO WATER DISTRICT							
80 102820	INVOICE: WATER 11/01/20	STATUS: Printed					
10193		WATER	STA 60 ME 10/28/20 (25650)	357-9557-795-30-00-WF		606.79	
* 80 102820 Subtotal						<u>606.79</u>	
81 102820	INVOICE: WATER 10/28/20	STATUS: Printed					
10193		WATER	FS Bldg ME 10/28/20 (307)	357-9557-795-30-00-WF		49.72	
* 81 102820 Subtotal						<u>49.72</u>	
** CALL001 Subtotal (2 Invoices)						<b>656.51</b>	
COBB001 VENDOR: COBB AREA CO WATER DISTRICT							
185 10/21/20	INVOICE: WATER 10/23/20	STATUS: Printed					
10194		WATER	STA 62 ME 10/21/20 (10,000)	357-9557-795-30-00-W2		124.44	
* 185 10/21/20 Subtotal						<u>124.44</u>	
** COBB001 Subtotal (1 Invoice)						<b>124.44</b>	
COUN002 VENDOR: COUNTY OF LAKE SOLID WASTE							
04-00432735	INVOICE: GARBAGE DISPOSAL 11/03/20	STATUS: Printed					
10196		GARBAGE DISPOSAL	FS BLDG (2720 LB)	357-9557-795-30-00-GF		86.10	
* 04-00432735 Subtotal						<u>86.10</u>	
** COUN002 Subtotal (1 Invoice)						<b>86.10</b>	
COUNTYIT VENDOR: COUNTY OF LAKE INFORMATION TECHNOLOGY							
Q1-20/21	INVOICE: DATA COLLECTION 10/22/20	STATUS: Printed					
10195		DATA COLLECTION	2020 DIRECT CHARGE	357-9557-795-23-80-SP		135.00	
* Q1-20/21 Subtotal						<u>135.00</u>	
** COUNTYIT Subtotal (1 Invoice)						<b>135.00</b>	
COZADDIAN VENDOR: DIANA COZADD							
050243090000	INVOICE: OVERPAYMENT REFUND 11/06/20	STATUS: Printed					
10198		OVERPAYMENT REFUND	2019		357-9557-466-69-29-CF	40.00	
* 050243090000 Subtotal						<u>40.00</u>	
** COZADDIAN Subtotal (1 Invoice)						<b>40.00</b>	
FECH001 VENDOR: FECHTER & COMPANY CPAS							
2018 90%	INVOICE: 2018 FYE AUDIT 10/29/20	STATUS: Printed					
10199		2018 FYE AUDIT	90% COMPLETE	357-9557-795-23-80-SP		1,097.00	
* 2018 90% Subtotal						<u>1,097.00</u>	
** FECH001 Subtotal (1 Invoice)						<b>1,097.00</b>	



Voucher No	Merchant Vendor Name	Invoice Description	Line Item Description	Budget Exp Acct	Budget Rev Acct	Line Net Amt	Req No / Descr 2
LAKE001	VENDOR: LAKE COUNTY EMPLOYEES' ASSN						
	HORST DEC2020 INVOICE: OPEB 12/01/20 STATUS: Printed						
	10200	OPEB	DEC 2020 - HORST DUES	357-9557-795-03-30-R		31.64	
	<b>* HORST DEC2020 Subtotal</b>					<b>31.64</b>	
	<b>** LAKE001 Subtotal (1 Invoice)</b>					<b>31.64</b>	
LAKE003	VENDOR: LAKE COUNTY SPECIAL DISTRICTS						
	2200820 12/15/20 INVOICE: SEWER 10/16/20 STATUS: Printed						
	10201	SEWER	FS BLDG ME 12/15/20 (0)	357-9557-795-30-00-SF		32.60	
	<b>* 2200820 12/15/20 Subtotal</b>					<b>32.60</b>	
	2202596 12/15/20 INVOICE: SEWER 10/16/20 STATUS: Printed						
	10201	SEWER	FS BLDG ME 12/15/20 (0)	357-9557-795-30-00-SF		32.60	
	<b>* 2202596 12/15/20 Subtotal</b>					<b>32.60</b>	
	<b>** LAKE003 Subtotal (2 Invoices)</b>					<b>65.20</b>	
LIFE001	VENDOR: LIFE ASSIST INC						
	1045137 INVOICE: EMS SUPPLIES 10/26/20 STATUS: Printed						
	10202	EMS SUPPLIES	PO 112520	357-9557-795-19-40-MS		1,738.97	
	<b>* 1045137 Subtotal</b>					<b>1,738.97</b>	
	1046180 INVOICE: EMS SUPPLIES 10/28/20 STATUS: Printed						
	10202	EMS SUPPLIES	Ord # 60206261-1	357-9557-795-19-40-MS		489.92	
	<b>* 1046180 Subtotal</b>					<b>489.92</b>	
	1048266 INVOICE: EMS SUPPLIES 11/05/20 STATUS: Printed						
	10202	EMS SUPPLIES	PO 112520	357-9557-795-19-40-MS		5.02	
	<b>* 1048266 Subtotal</b>					<b>5.02</b>	
	<b>** LIFE001 Subtotal (3 Invoices)</b>					<b>2,233.91</b>	
LOCH001	VENDOR: LOCH LOMOND MUTUAL WATER						
	31 11/19/20 INVOICE: WATER 11/20/20 STATUS: Printed						
	10203	WATER	STA 64 ME 11/20/20 (0)	357-9557-795-30-00-W4		125.00	
	<b>* 31 11/19/20 Subtotal</b>					<b>125.00</b>	
	<b>** LOCH001 Subtotal (1 Invoice)</b>					<b>125.00</b>	
MAHO001	VENDOR: DENNIS MAHONEY						
	110 INVOICE: LANDSCAPE MAINTENANC 10/12/20 STATUS: Printed						
	10197	LANDSCAPE MAINTENANCE	STA 60 09/17/20	357-9557-795-18-00-60		75.00	
	10197	LANDSCAPE MAINTENANCE	STA 60 10/08/20	357-9557-795-18-00-60		75.00	
	<b>* 110 Subtotal</b>					<b>150.00</b>	
	111 INVOICE: LANDSCAPE MAINTENANC 11/06/20 STATUS: Printed						
	10197	LANDSCAPE MAINTENANCE	STA 60 10/29/20	357-9557-795-18-00-60		75.00	
	10197	LANDSCAPE MAINTENANCE	STA 60 11/06/20	357-9557-795-18-00-60		75.00	
	<b>* 111 Subtotal</b>					<b>150.00</b>	
	<b>** MAHO001 Subtotal (2 Invoices)</b>					<b>300.00</b>	
MERR001	VENDOR: MERRILL ARNONE & JONES LLP						
	1020150 INVOICE: LEGAL EXPENSES 11/01/20 STATUS: Printed						
	10204	LEGAL EXPENSES	10/01/20-10/31/20	357-9557-795-23-80-SP		2,198.10	
	<b>* 1020150 Subtotal</b>					<b>2,198.10</b>	
	<b>** MERR001 Subtotal (1 Invoice)</b>					<b>2,198.10</b>	
NORT001	VENDOR: NORTH COAST EMS						
	0101-063020 INVOICE: IMAGE TREND ELITE 10/16/20 STATUS: Printed						
	10205	IMAGE TREND ELITE	JAN-JUNE 2020	357-9557-795-28-48-NC		348.23	
	<b>* 0101-063020 Subtotal</b>					<b>348.23</b>	
	<b>** NORT001 Subtotal (1 Invoice)</b>					<b>348.23</b>	
OPER001	VENDOR: OPERATING ENGINEERS						
	HORST DEC 2020 INVOICE: OPEB 12/01/20 STATUS: Printed						
	10206	OPEB	DEC 2020 - HORST HEALTH INS	357-9557-795-03-30-R		1,497.00	
	<b>* HORST DEC 2020 Subtotal</b>					<b>1,497.00</b>	
	<b>** OPER001 Subtotal (1 Invoice)</b>					<b>1,497.00</b>	
PG&E001	VENDOR: PG&E						
	69913707415 1021 INVOICE: ELECTRIC CHGS 10/22/20 STATUS: Printed						
	10207	ELECTRIC CHGS	STA 62 ME 10/21/20 (2283.538800 kWh)	357-9557-795-30-00-E2		587.24	
	10207	ELECTRIC CHGS	FS Bldg ME 10/21/20 (791.283500 kWh)	357-9557-795-30-00-EF		224.13	
	10207	ELECTRIC CHGS	STA 64 ME 10/21/20 (353.261000 kWh)	357-9557-795-30-00-E4		114.38	
	10207	ELECTRIC CHGS	STA 60 ME 10/21/20 (6581.000000 kWh)	357-9557-795-30-00-E0		1,708.28	
	10207	ELECTRIC CHGS	STA 63 ME 10/21/20 (2270.649000 kWh)	357-9557-795-30-00-E3		590.60	
	<b>* 69913707415 1021 Subtotal</b>					<b>3,224.63</b>	
	<b>** PG&amp;E001 Subtotal (1 Invoice)</b>					<b>3,224.63</b>	
PRATHERMIC	VENDOR: MICHAEL R PRATHER						
	115014190-2019 INVOICE: REFUND 2019 ASSESSME 11/05/20 STATUS: Printed						
	10189	REFUND 2019 ASSESSMENT	REFUND 2019 ASSESSMENT		357-9557-466-69-29-CS	200.00	
	<b>* 115014190-2019 Subtotal</b>					<b>200.00</b>	
	<b>** PRATHERMIC Subtotal (1 Invoice)</b>					<b>200.00</b>	
SOUT002	VENDOR: SOUTH LAKE COUNTY FIRE PROTECTION DIST						
	PPE 093020 INVOICE: PPE 09/30/20 10/15/20 STATUS: Printed						
	10188	PPE 09/30/20	PPE 09/30/20	357-9557-795-09-00-00		43,281.66	
	<b>* PPE 093020 Subtotal</b>					<b>43,281.66</b>	
	<b>** SOUT002 Subtotal (1 Invoice)</b>					<b>43,281.66</b>	
USBA001	VENDOR: US BANK						
	030499018637 INVOICE: NEW FREEZER 09/04/20 STATUS: Printed						
	10210 SEARS	NEW FREEZER	STA 63 GE FREEZER FUF17SMRWW	357-9557-795-18-00-63		948.19	
	<b>* 030499018637 Subtotal</b>					<b>948.19</b>	

Voucher No	Merchant Vendor Name	Invoice Description	Line Item Description	Budget Exp Acct	Budget Rev Acct	Line Net Amt	Req No / Descr 2
USBA001	VENDOR: US BANK						
109997	INVOICE: FIRE SUPPRESSION SUP 08/25/20 STATUS: Printed						
10210	CASCADE FIRE EQUIPMENT COMPANY	FIRE SUPPRESSION SUPPLY	5 GAL SMOKECHASER BACK PUMP	357-9557-795-28-30-AB		1,798.76	LNU LIGHTNING COMPLEX
<b>* 109997 Subtotal</b>						<b>1,798.76</b>	
131336695-001	INVOICE: OFFICE EQT 10/14/20 STATUS: Printed						
10210	OFFICE DEPOT	OFFICE EQT	STA 63 MONITOR STAND	357-9557-795-22-70-63		37.53	
<b>* 131336695-001 Subtotal</b>						<b>37.53</b>	
131337320-001	INVOICE: OFFICE EQT 10/14/20 STATUS: Printed						
10210	OFFICE DEPOT	OFFICE EQT	STA 63 DESK CHAIR	357-9557-795-22-70-63		246.65	
<b>* 131337320-001 Subtotal</b>						<b>246.65</b>	
30128147 111620	INVOICE: INTERNET SVC 10/07/20 STATUS: Printed						
10210	MEDIACOM	INTERNET SVC	STA 63 ME 11/16/20	357-9557-795-30-00-I3		68.18	
<b>* 30128147 111620 Subtotal</b>						<b>68.18</b>	
S0585574	INVOICE: EQT TO PLACE ENGINE 09/03/20 STATUS: Printed						
10210	LN CURTIS & SONS	EQT TO PLACE ENGINE IN SERVICE	E6031 FF SHUT-OFF CLAMP SGL JACKET	357-9557-795-28-30-60		436.16	
10210	LN CURTIS & SONS	EQT TO PLACE ENGINE IN SERVICE	E6032 FF SHUT-OFF CLAMP SGL JACKET	357-9557-795-28-30-60		872.31	
<b>* S0585574 Subtotal</b>						<b>1,308.47</b>	
<b>** USBA001 Subtotal (6 Invoices)</b>						<b>4,407.78</b>	
USBA002	VENDOR: U.S.BANK						
0020-0293	INVOICE: FORCE ENTRY TRAIN DO 10/28/20 STATUS: Printed						
10211	FORCIBLE ENTRY EQUIPMENT	FORCE ENTRY TRAIN DOOR	FORCE ENTRY TRAIN DOOR	357-9557-795-18-00-T		6,484.63	FIRE SIREN WISHLIST 2020
<b>* 0020-0293 Subtotal</b>						<b>6,484.63</b>	
017335	INVOICE: INFORMATIONAL HANDOU 10/22/20 STATUS: Printed						
10211	MIDDLETOWN COPY & PRINT	INFORMATIONAL HANDOUT	STA 62 WHAT TO DO WHEN SOMEONE DIES	357-9557-795-28-48-62		115.30	
10211	MIDDLETOWN COPY & PRINT	INFORMATIONAL HANDOUT	STA 63 WHAT TO DO WHEN SOMEONE DIES	357-9557-795-28-48-63		115.29	
<b>* 017335 Subtotal</b>						<b>230.59</b>	
02-116796 103120	INVOICE: REFUSE/RECYCLE COLLE 10/31/20 STATUS: Printed						
10211	SOUTH LAKE REFUSE	REFUSE/RECYCLE COLLECTION	STA 62 ME 10/31/20	357-9557-795-30-00-G2		68.73	
<b>* 02-116796 103120 Subtotal</b>						<b>68.73</b>	
02-152940 103120	INVOICE: REFUSE/RECYCLE COLLE 10/31/20 STATUS: Printed						
10211	SOUTH LAKE REFUSE	REFUSE/RECYCLE COLLECTION	STA 60 ME 10/31/20	357-9557-795-30-00-G0		303.42	
<b>* 02-152940 103120 Subtotal</b>						<b>303.42</b>	
02-601722 103120	INVOICE: REFUSE/RECYCLE COLLE 10/31/20 STATUS: Printed						
10211	SOUTH LAKE REFUSE	REFUSE/RECYCLE COLLECTION	STA 63 ME 10/31/20	357-9557-795-30-00-G3		81.42	
<b>* 02-601722 103120 Subtotal</b>						<b>81.42</b>	
02249	INVOICE: KITCHEN APPLIANCE RE 10/26/20 STATUS: Printed						
10211	WALMART	KITCHEN APPLIANCE REPLACEMENT	STA 62 TOASTER	357-9557-795-14-00-62		21.71	
10211	WALMART	KITCHEN APPLIANCE REPLACEMENT	STA 62 BRUSH	357-9557-795-14-00-62		8.57	
<b>* 02249 Subtotal</b>						<b>30.28</b>	
028230	INVOICE: CHAINSAW REPAIR 11/07/20 STATUS: Printed						
10211	RAINBOW AMERICA'S COUNTRY STORE	CHAINSAW REPAIR	OES359 STIHIL CHAINSAW SCRENCH	357-9557-795-27-00-60		10.70	
<b>* 028230 Subtotal</b>						<b>10.70</b>	
06197	INVOICE: YARD MAINTENANCE 10/23/20 STATUS: Printed						
10211	LAYNE PAVING AND TRUCKING	YARD MAINTENANCE	STA 60 6YDS BARK	357-9557-795-18-00-60		505.69	
<b>* 06197 Subtotal</b>						<b>505.69</b>	
111068	INVOICE: INCREASE ONE PERSON 10/01/20 STATUS: Printed						
10211	CASCADE FIRE EQUIPMENT COMPANY	INCREASE ONE PERSON STAFF ABILITY	WT6411 AKRON REMOTE CONTROL MONITOR	357-9557-795-17-00-64		8,384.71	
<b>* 111068 Subtotal</b>						<b>8,384.71</b>	
1113259946	INVOICE: PROPANE 10/26/20 STATUS: Printed						
10211	FERRELLGAS	PROPANE	STA 60 FILL 10/26/20	357-9557-795-30-00-P0		738.37	
<b>* 1113259946 Subtotal</b>						<b>738.37</b>	
11247	INVOICE: ANNUAL TESTING 11/03/20 STATUS: Printed						
10211	FAILSAFE TESTING LLC	ANNUAL TESTING	STA 60 GROUND LADDERS	357-9557-795-17-00-60		515.85	
10211	FAILSAFE TESTING LLC	ANNUAL TESTING	STA 62 GROUND LADDERS	357-9557-795-17-00-62		208.05	
10211	FAILSAFE TESTING LLC	ANNUAL TESTING	STA 63 GROUND LADDERS	357-9557-795-17-00-63		208.05	
10211	FAILSAFE TESTING LLC	ANNUAL TESTING	STA 64 GROUND LADDERS	357-9557-795-17-00-64		208.05	
10211	FAILSAFE TESTING LLC	ANNUAL TESTING	STA 31 GROUND LADDERS	357-9557-795-17-00-A		114.00	
<b>* 11247 Subtotal</b>						<b>1,254.00</b>	
1350142	INVOICE: VOL INSURANCE COVERA 10/14/20 STATUS: Printed						
10211	MYERS-STEVENS & TOOHEY & CO	VOL INSURANCE COVERAGE	INJ / ILLNESS / INCOME PROTECTION	357-9557-795-03-30-I		2,738.00	
<b>* 1350142 Subtotal</b>						<b>2,738.00</b>	
157417	INVOICE: MAINTAIN ORANGE BOX 11/06/20 STATUS: Printed						
10211	INTERSTATE ALL BATTERY CENTER	MAINTAIN ORANGE BOX LIGHTS	OES359 SEALED RECHARGEABLE BATTERIE	357-9557-795-18-00-63		98.63	
<b>* 157417 Subtotal</b>						<b>98.63</b>	
2197	INVOICE: FIRE MAPS/BOOKLETS 08/31/20 STATUS: Printed						
10211	MIDDLETOWN COPY & PRINT	FIRE MAPS/BOOKLETS	FIRE MAPS, BOOKLETS, IAP BRANCH	357-9557-795-12-00-60		298.91	LNU LIGHTNING COMPLEX
<b>* 2197 Subtotal</b>						<b>298.91</b>	
22375879	INVOICE: MEDICAL OXYGEN RENTA 09/30/20 STATUS: Printed						
10211	MATHESON TRI-GAS INC	MEDICAL OXYGEN RENTAL	ME 09/30/20	357-9557-795-19-40-0		30.95	
<b>* 22375879 Subtotal</b>						<b>30.95</b>	
22534883	INVOICE: MEDICAL OXYGEN RENTA 10/31/20 STATUS: Printed						
10211	MATHESON TRI-GAS INC	MEDICAL OXYGEN RENTAL	ME 10/31/20	357-9557-795-19-40-0		31.77	
<b>* 22534883 Subtotal</b>						<b>31.77</b>	

Voucher No	Merchant Vendor Name	Invoice Description	Line Item Description	Budget Exp Acct	Budget Rev Acct	Line Net Amt	Req No / Descr 2
USBA002	VENDOR: U.S.BANK						
228002	INVOICE: EQT TO PLACE ENGINE 11/12/20 STATUS: Printed						
10211	ALLSTAR FIRE EQUIPMENT INC	EQT TO PLACE ENGINE IN SERVICE	E6031 ELKHART 04XD012F CHIEF XD NO2	357-9557-795-17-00-60		666.32	
10211	ALLSTAR FIRE EQUIPMENT INC	EQT TO PLACE ENGINE IN SERVICE	E6032 ELKHART 04XD012F CHIEF XD NO2	357-9557-795-28-30-60		1,332.63	
10211	ALLSTAR FIRE EQUIPMENT INC	EQT TO PLACE ENGINE IN SERVICE	E6032 KEY DP17-100S COMBAT SNIPER D	357-9557-795-28-30-60		916.74	
<b>* 228002 Subtotal</b>						<b>2,915.69</b>	
2451159	CR INVOICE: CLEANING SUPPLIES 09/02/20 STATUS: Printed						
10211	KELSEYVILLE LUMBER	CLEANING SUPPLIES	STA 62 FILTRETRE DUST/POLLEN FILTER	357-9557-795-14-00-62		-141.44	
10211	KELSEYVILLE LUMBER	CLEANING SUPPLIES	STA 62 BEHRENS GALV GARBAGE CAN 20G	357-9557-795-14-00-62		-27.87	
10211	KELSEYVILLE LUMBER	CLEANING SUPPLIES	STA 62 FORNEY 6" WHIRE WHEEL BRUSH	357-9557-795-14-00-62		-9.32	
10211	KELSEYVILLE LUMBER	CLEANING SUPPLIES	STA 62 LIQUID CAR/TRUCK WASH 1GAL	357-9557-795-14-00-62		-21.43	
10211	KELSEYVILLE LUMBER	CLEANING SUPPLIES	STA 62 GOLD CLASS CARNAUBA WAX	357-9557-795-14-00-62		-15.01	
<b>* 2451159 CR Subtotal</b>						<b>-215.07</b>	
2907	INVOICE: ICE MACHINE REPAIR 10/06/20 STATUS: Printed						
10211	HEDGE APPLIANCE SERVICE	ICE MACHINE REPAIR	STA 63 TRIP CHARGE/DIAGNOSIS	357-9557-795-17-00-63		80.00	
<b>* 2907 Subtotal</b>						<b>80.00</b>	
30165883	112620 INVOICE: INTERNET SVC 10/17/20 STATUS: Printed						
10211	MEDIACOM	INTERNET SVC	STA 62 ME 11/26/20	357-9557-795-30-00-I2		68.18	
10211	MEDIACOM	INTERNET SVC	STA 62 OVERAGE ME 10/26/20	357-9557-795-30-00-I2		40.00	
<b>* 30165883 112620 Subtotal</b>						<b>108.18</b>	
30173705	112620 INVOICE: INTERNET SVC 10/17/20 STATUS: Printed						
10211	MEDIACOM	INTERNET SVC	STA 60 ME 11/26/20	357-9557-795-30-00-I0		57.99	
<b>* 30173705 112620 Subtotal</b>						<b>57.99</b>	
433518	INVOICE: SCBA UNIT REPAIR 10/21/20 STATUS: Printed						
10211	LN CURTIS & SONS	SCBA UNIT REPAIR	LABOR	357-9557-795-17-00-60		254.88	
10211	LN CURTIS & SONS	SCBA UNIT REPAIR	REBUILD KIT YVA 3010 LINE VALVE	357-9557-795-17-00-60		32.62	
10211	LN CURTIS & SONS	SCBA UNIT REPAIR	17 LITER CALIBRATION GAS	357-9557-795-17-00-60		113.17	
10211	LN CURTIS & SONS	SCBA UNIT REPAIR	VALVE REPLACEMENT KNOB	357-9557-795-17-00-60		8.16	
10211	LN CURTIS & SONS	SCBA UNIT REPAIR	MILEAGE	357-9557-795-17-00-60		61.17	
10211	LN CURTIS & SONS	SCBA UNIT REPAIR	TRAVEL	357-9557-795-17-00-60		101.95	
<b>* 433518 Subtotal</b>						<b>571.95</b>	
447609	INVOICE: BROKEN ELECTRIC FIXT 10/21/20 STATUS: Printed						
10211	HARDESTERS	BROKEN ELECTRIC FIXT REPR	STA 64 WALPLAT 1G DCR WH 10	357-9557-795-18-00-64		7.07	
10211	HARDESTERS	BROKEN ELECTRIC FIXT REPR	STA 64 OCCUPANCY SENSOR WHT	357-9557-795-18-00-64		27.87	
10211	HARDESTERS	BROKEN ELECTRIC FIXT REPR	STA 64 DECOR DFLX TR OUT20A	357-9557-795-18-00-64		48.85	
10211	HARDESTERS	BROKEN ELECTRIC FIXT REPR	STA 64 SWITCH QT WH 15A120/	357-9557-795-18-00-64		9.63	
10211	HARDESTERS	BROKEN ELECTRIC FIXT REPR	STA 64 SWITCH SP WHT20A120/	357-9557-795-18-00-64		45.01	
10211	HARDESTERS	BROKEN ELECTRIC FIXT REPR	STA 64 DECOR WALLPLAGE 1 G	357-9557-795-18-00-64		2.98	
10211	HARDESTERS	BROKEN ELECTRIC FIXT REPR	STA 64 BLANK WALLPLATE 1G W	357-9557-795-18-00-64		5.31	
10211	HARDESTERS	BROKEN ELECTRIC FIXT REPR	STA 64 RECEPTACLE WALLPLATE	357-9557-795-18-00-64		2.99	
<b>* 447609 Subtotal</b>						<b>149.71</b>	
454908	INVOICE: ELECTRICAL REPAIR 10/02/20 STATUS: Printed						
10211	HARDESTERS	ELECTRICAL REPAIR	STA 60 ELECTRICAL PLUG ADAPTERS	357-9557-795-18-00-60		237.60	
<b>* 454908 Subtotal</b>						<b>237.60</b>	
457105	INVOICE: ELECTRICAL REPAIR 10/13/20 STATUS: Printed						
10211	HARDESTERS	ELECTRICAL REPAIR	STA 64 PAD KNEE RRO NO MARK	357-9557-795-18-00-64		27.88	
10211	HARDESTERS	ELECTRICAL REPAIR	STA 64 SNIPS MULTIPURP 9 V	357-9557-795-18-00-64		20.37	
10211	HARDESTERS	ELECTRICAL REPAIR	STA 64 SCRAPER BENT 3THREAD	357-9557-795-18-00-64		10.71	
<b>* 457105 Subtotal</b>						<b>58.96</b>	
457182	INVOICE: WASHING SUPPLIES 10/17/20 STATUS: Printed						
10211	HARDESTERS	WASHING SUPPLIES	STA 60 ROPE NYLON S.BRD 1/4	357-9557-795-17-00-60		21.44	
10211	HARDESTERS	WASHING SUPPLIES	STA 60 STONE TILE LAM CLNR	357-9557-795-17-00-60		12.86	
10211	HARDESTERS	WASHING SUPPLIES	STA 60 PAD FELT 1.5 VALVE	357-9557-795-17-00-60		8.14	
10211	HARDESTERS	WASHING SUPPLIES	STA 60 WASHER TAILPC1.5 SJ	357-9557-795-17-00-60		2.56	
10211	HARDESTERS	WASHING SUPPLIES	STA 60 SNAP TRIGGR RND2-9/1	357-9557-795-17-00-60		14.55	
<b>* 457182 Subtotal</b>						<b>59.55</b>	
48912	INVOICE: PEST CONTROL 10/14/20 STATUS: Printed						
10211	ARMED FORCE PEST CONTROL	PEST CONTROL	STA 63 GENERAL PEST	357-9557-795-18-00-63		90.00	
<b>* 48912 Subtotal</b>						<b>90.00</b>	
4957940	INVOICE: NEW BOARD MEMBER BAD 11/10/20 STATUS: Printed						
10211	MALLORY SAFETY AND SUPPLY LLC	NEW BOARD MEMBER BADGE	REDFORD BADGE	357-9557-795-11-00-U		76.87	
10211	MALLORY SAFETY AND SUPPLY LLC	NEW BOARD MEMBER BADGE	REDFORD BADGE HOLDER	357-9557-795-11-00-U		24.16	
<b>* 4957940 Subtotal</b>						<b>101.03</b>	
50050000	103020 INVOICE: WATER/SEWER 11/02/20 STATUS: Printed						
10211	HIDDEN VALLEY LAKE CSD	WATER/SEWER	STA 63 WATER ME 10/30/20 (422)	357-9557-795-30-00-W3		50.89	
10211	HIDDEN VALLEY LAKE CSD	WATER/SEWER	STA 63 SEWER ME 10/30/20	357-9557-795-30-00-W3		64.94	
<b>* 50050000 103020 Subtotal</b>						<b>115.83</b>	
51475782	INVOICE: BOARD MEETING REMOTE 11/11/20 STATUS: Printed						
10211	ZOOM VIDEO COMMUNICATIONS INC	BOARD MEETING REMOTE ACCESS	ME 12/10/20, STANDARD PRO	357-9557-795-23-80-SP		14.99	
<b>* 51475782 Subtotal</b>						<b>14.99</b>	
5397	INVOICE: BOOTS 09/12/20 STATUS: Printed						
10211	CAMPOS CASUALS	BOOTS	J.LEUZINGER - CAROLINA	357-9557-795-11-00-B		152.24	
<b>* 5397 Subtotal</b>						<b>152.24</b>	
60231	INVOICE: PORTABLE TOILET SERV 10/22/20 STATUS: Printed						
10211	ACTION SANITARY	PORTABLE TOILET SERVICE	CUSTOMER OWNED OCTOBER	357-9557-795-18-00-60		50.00	
<b>* 60231 Subtotal</b>						<b>50.00</b>	

Voucher No	Merchant Vendor Name	Invoice Description	Line Item Description	Budget Exp Acct	Budget Rev Acct	Line Net Amt	Req No / Descr 2
USBA002	VENDOR: U.S.BANK						
893300	INVOICE: COPIER MAINT 10/06/20 STATUS: Printed						
10211	SMILE BUSINESS PRODUCTS	COPIER MAINT	STA 60 QE 09/30/20 METER END157250	357-9557-795-17-00-60		292.23	
<b>* 893300 Subtotal</b>						<b>292.23</b>	
94768	INVOICE: HOUSEHOLD SUPPLIES 10/09/20 STATUS: Printed						
10211	BOBS VACUUM	HOUSEHOLD SUPPLIES	STA60 S-FOLD TOWELS	357-9557-795-14-00-60		115.62	
10211	BOBS VACUUM	HOUSEHOLD SUPPLIES	STA60 DAWN	357-9557-795-14-00-60		81.51	
10211	BOBS VACUUM	HOUSEHOLD SUPPLIES	STA60 CLOROX	357-9557-795-14-00-60		115.83	
10211	BOBS VACUUM	HOUSEHOLD SUPPLIES	STA60 LYSOL DISINF WIPES	357-9557-795-14-00-60		102.83	
10211	BOBS VACUUM	HOUSEHOLD SUPPLIES	STA60 DRYER SHEETS	357-9557-795-14-00-60		19.14	
10211	BOBS VACUUM	HOUSEHOLD SUPPLIES	STA60 SPRAYER TOP	357-9557-795-14-00-60		10.72	
10211	BOBS VACUUM	HOUSEHOLD SUPPLIES	STA60 TOILET BRUSH	357-9557-795-14-00-60		10.26	
10211	BOBS VACUUM	HOUSEHOLD SUPPLIES	STA60 LONG WHITE BRUSH	357-9557-795-14-00-60		11.69	
10211	BOBS VACUUM	HOUSEHOLD SUPPLIES	STA60 TRUCK BRUSH	357-9557-795-14-00-60		32.18	
<b>* 94768 Subtotal</b>						<b>499.79</b>	
94916	INVOICE: HOUSEHOLD SUPPLIES 11/05/20 STATUS: Printed						
10211	BOBS VACUUM	HOUSEHOLD SUPPLIES	STA 63 S-FOLD TOWELS	357-9557-795-14-00-63		28.90	
10211	BOBS VACUUM	HOUSEHOLD SUPPLIES	STA 63 TOILET BOWL CLEANER	357-9557-795-14-00-63		17.70	
10211	BOBS VACUUM	HOUSEHOLD SUPPLIES	STA 63 CASCADE COMPLETE	357-9557-795-14-00-63		61.10	
<b>* 94916 Subtotal</b>						<b>107.70</b>	
949167	INVOICE: EMERG EXIT INSTALL 11/05/20 STATUS: Printed						
10211	WEIDNERS WELDING	EMERG EXIT INSTALL	STA 63 MATERIAL	357-9557-795-18-00-63		1,339.97	
10211	WEIDNERS WELDING	EMERG EXIT INSTALL	STA 63 LABO	357-9557-795-18-00-63		2,300.00	
<b>* 949167 Subtotal</b>						<b>3,639.97</b>	
9865815976	INVOICE: CELLULAR SVC 10/26/20 STATUS: Printed						
10211	VERIZON WIRELESS	CELLULAR SVC	M6211 ME 11/26/20 Booster Extender	357-9557-795-12-00-62		38.01	
10211	VERIZON WIRELESS	CELLULAR SVC	M6311 ME 11/26/20 Booster Extender	357-9557-795-12-00-63		38.01	
10211	VERIZON WIRELESS	CELLULAR SVC	M6211 ME 11/26/20 Tablet	357-9557-795-12-00-62		38.01	
10211	VERIZON WIRELESS	CELLULAR SVC	B1417 ME 11/26/20 Tablet	357-9557-795-12-00-A		16.02	
10211	VERIZON WIRELESS	CELLULAR SVC	B1418 ME 11/26/20 Tablet	357-9557-795-12-00-A		16.02	
10211	VERIZON WIRELESS	CELLULAR SVC	M6011 ME 11/26/20 Tablet	357-9557-795-12-00-60		16.02	
10211	VERIZON WIRELESS	CELLULAR SVC	E1487 ME 11/26/20 Tablet	357-9557-795-12-00-A		16.02	
10211	VERIZON WIRELESS	CELLULAR SVC	M6311 ME 11/26/20 Tablet	357-9557-795-12-00-63		16.02	
10211	VERIZON WIRELESS	CELLULAR SVC	M6012 ME 11/26/20 Cell Phone	357-9557-795-12-00-60		0.53	
10211	VERIZON WIRELESS	CELLULAR SVC	OES359 ME 11/26/20 Cell Phone	357-9557-795-12-00-60		0.53	
10211	VERIZON WIRELESS	CELLULAR SVC	Spare ME 11/26/20 Cell Phone	357-9557-795-12-00-60		0.53	
10211	VERIZON WIRELESS	CELLULAR SVC	M6011 ME 11/26/20 Cell Phone	357-9557-795-12-00-60		0.53	
10211	VERIZON WIRELESS	CELLULAR SVC	M6211 ME 11/26/20 Cell Phone	357-9557-795-12-00-62		0.53	
10211	VERIZON WIRELESS	CELLULAR SVC	M6311 ME 11/26/20 Cell Phone	357-9557-795-12-00-63		0.53	
<b>* 9865815976 Subtotal</b>						<b>197.31</b>	
CMS-PMT-14658	INVOICE: CPS RECERT FEE 10/29/20 STATUS: Printed						
10211	SAFE KIDS WORLDWIDE	CPS RECERT FEE	FONG CPS RECERT FEE EXP 10/30/22	357-9557-795-28-30-L		55.00	
<b>* CMS-PMT-14658 Subtotal</b>						<b>55.00</b>	
ORD324752	INVOICE: EQT TO PLACE ENGINE 10/01/20 STATUS: Printed						
10211	FORESTRY SUPPLIERS	EQT TO PLACE ENGINE IN SERVICE	E6032 SINGLE BIT AXE	357-9557-795-28-30-60		67.95	
10211	FORESTRY SUPPLIERS	EQT TO PLACE ENGINE IN SERVICE	E6032 TACTICAL SHOULDER BAG	357-9557-795-28-30-60		57.99	
10211	FORESTRY SUPPLIERS	EQT TO PLACE ENGINE IN SERVICE	E6032 FUEL BOTTLE 30 OZ	357-9557-795-28-30-60		47.90	
10211	FORESTRY SUPPLIERS	EQT TO PLACE ENGINE IN SERVICE	E6032 GARMIN GPSMAP 64SX	357-9557-795-28-30-60		349.99	
10211	FORESTRY SUPPLIERS	EQT TO PLACE ENGINE IN SERVICE	E6032 TEXTURE FELLING WEDGE 5.5"	357-9557-795-28-30-60		7.95	
10211	FORESTRY SUPPLIERS	EQT TO PLACE ENGINE IN SERVICE	E6032 HARDHEAD FELLING WEDGE 7.5"	357-9557-795-28-30-60		8.95	
10211	FORESTRY SUPPLIERS	EQT TO PLACE ENGINE IN SERVICE	E6032 HARDHEAD FELLING WEDGE 10"	357-9557-795-28-30-60		10.95	
10211	FORESTRY SUPPLIERS	EQT TO PLACE ENGINE IN SERVICE	E6032 FIRE WEATHER INSTRUMENT KIT	357-9557-795-28-30-60		132.50	
10211	FORESTRY SUPPLIERS	EQT TO PLACE ENGINE IN SERVICE	E6031 SINGLE BIT AXE	357-9557-795-28-30-60		67.95	
10211	FORESTRY SUPPLIERS	EQT TO PLACE ENGINE IN SERVICE	E6031 FUEL BOTTLE 30 OZ	357-9557-795-28-30-60		47.90	
10211	FORESTRY SUPPLIERS	EQT TO PLACE ENGINE IN SERVICE	E6031 TEXTURE FELLING WEDGE 5.5"	357-9557-795-28-30-60		7.95	
10211	FORESTRY SUPPLIERS	EQT TO PLACE ENGINE IN SERVICE	E6031 HARDHEAD FELLING WEDGE 7.5"	357-9557-795-28-30-60		8.95	
10211	FORESTRY SUPPLIERS	EQT TO PLACE ENGINE IN SERVICE	E6031 HARDHEAD FELLING WEDGE 10"	357-9557-795-28-30-60		10.95	
10211	FORESTRY SUPPLIERS	EQT TO PLACE ENGINE IN SERVICE	E6031 FIRE WEATHER INSTRUMENT KIT	357-9557-795-28-30-60		132.50	
<b>* ORD324752 Subtotal</b>						<b>960.38</b>	
<b>** USBA002 Subtotal (39 Invoices)</b>						<b>31,591.83</b>	
USBA003	VENDOR: US BANK VOYAGER FLEET SYS						
869083725043	INVOICE: FUEL-GLASS FIRE 10/24/20 STATUS: Printed						
10208	FUEL-GLASS FIRE	FUEL-GLASS FIRE	U1426 10/02/20	357-9557-795-29-50-C		56.42	
10208	FUEL-GLASS FIRE	FUEL-GLASS FIRE	U1426 10/04/20	357-9557-795-29-50-C		63.46	
10208	FUEL-GLASS FIRE	FUEL-GLASS FIRE	U1426 10/08/20	357-9557-795-29-50-C		52.88	
10208	FUEL-GLASS FIRE	FUEL-GLASS FIRE	U1426 10/18/20	357-9557-795-29-50-C		51.84	
<b>* 869083725043 Subtotal</b>						<b>224.60</b>	
<b>** USBA003 Subtotal (1 Invoice)</b>						<b>224.60</b>	
WITTO01	VENDOR: WITTMAN ENTERPRISES						
2009043	INVOICE: AMBULANCE BILLING SV 10/28/20 STATUS: Printed						
10209	AMBULANCE BILLING SVC	AMBULANCE BILLING SVC	SEPTEMBER 2020	357-9557-795-23-80-AB		1,448.40	
<b>* 2009043 Subtotal</b>						<b>1,448.40</b>	
<b>** WITTO01 Subtotal (1 Invoice)</b>						<b>1,448.40</b>	
<b>*** Grand Total (72 Invoices)</b>						<b>99,243.59</b>	

COUNTY OF LAKE  
OFFICE OF THE AUDITOR-CONTROLLER

Grid of 20 empty boxes for tracking.

COUNTY OF LAKE

**BUDGET TRANSFER**

Fiscal Year: 2020-21

Budget Title: <u>South Lake County Fire Protection District</u>	Budget Transfer #B _____ (Auditor's Office Completes this section)
---	---

**TRANSFER FROM:**

**TRANSFER TO:**

From: Fund 357 Dept 9557  
(000) (0000)

To: Fund 357 Dept 9557  
(000) (0000)

<u>Account</u> <small>(000.00-00)</small>	<u>Account Title</u>	<u>Amount</u>
795.23-80	Prof & Specialized Svc	\$20000
_____	_____	\$ _____
_____	_____	\$ _____
_____	_____	\$ _____
_____	_____	\$ _____
_____	_____	\$ _____
_____	_____	\$ _____
_____	_____	\$ _____

<u>Account</u> <small>(000.00-00)</small>	<u>Account Title</u>	<u>Amount</u>
795.01-13	Salaries,Wages -OT	\$ 20000
_____	_____	\$ _____
_____	_____	\$ _____
_____	_____	\$ _____
_____	_____	\$ _____
_____	_____	\$ _____
_____	_____	\$ _____
_____	_____	\$ _____

*Department's justification & explanation of why transfer is necessary:*

Cover unanticipated overtime expense  
\_\_\_\_\_  
\_\_\_\_\_  
\_\_\_\_\_  
\_\_\_\_\_  
\_\_\_\_\_

Authorized Department Signature: *Stony*

Date: 11/18/20

APPROVED                       DENIED

CHAIRPERSON, DISTRICT \_\_\_\_\_ DATE \_\_\_\_\_

Auditor-Controller Use Only

Date \_\_\_\_\_ JE# \_\_\_\_\_ By: \_\_\_\_\_

*AKS*  
✓  
11/20/20